



INTERFACE SERIES

Installation & Operation Instructions
PTA2

Phone: 1-888-967-5224
Website: workaci.com

GENERAL INFORMATION

The PTA2 accepts a timed contact, or solid state closure, from a microprocessor controller and converts it to a linear analog output with 255 steps of resolution. The PTA2 will not wrap around if an excessively long pulse is received. Seven input pulse rates are jumper selectable (between Version 1 and 2). The input signal is optically isolated and can accept either positive or negative polarity. The PTA2 includes triac adapter circuitry (jumper selectable) for a triac input. The PTA2 has a jumper selectable manual override which will allow modulation of the output between 0-10 VDC to verify proper operation of the controlled device. On Version 1, the last output signal is held until the PTA2 receives the end of the next pulsed input signal.

MOUNTING INSTRUCTIONS

Circuit board may be mounted in any position. If circuit board slides out of snap track, a non-conductive "stop" may be required. Use

only fingers to remove board from snap track. Slide out of snap track or push against side of snap track and lift that side of the circuit board to remove. **Do not flex board or use tools.**

WIRING INSTRUCTIONS

PRECAUTIONS

- **Remove power before wiring. Never connect or disconnect wiring with power applied.**
- **When using a shielded cable, ground the shield only at the controller end. Grounding both ends can cause a ground loop.**
- **It is recommended you use an isolated UL-listed class 2 transformer when powering the unit with 24 VAC. Failure to wire the devices with the correct polarity when sharing transformers may result in damage to any device powered by the shared transformer.**
- **If the 24 VDC or 24VAC power is shared with devices that have coils such as relays, solenoids, or other inductors, each coil must have an MOV, DC/AC Transorb, Transient Voltage Suppressor (ACI Part: 142583), or diode placed across the coil or inductor. The cathode, or banded side of the DC Transorb or diode, connects to the positive side of the power supply. Without these snubbers, coils produce very large voltage spikes when de-energizing that can cause malfunction or destruction of electronic circuits.**
- **All wiring must comply with all local and National Electric Codes.**

FIGURE 1: DIMENSIONS

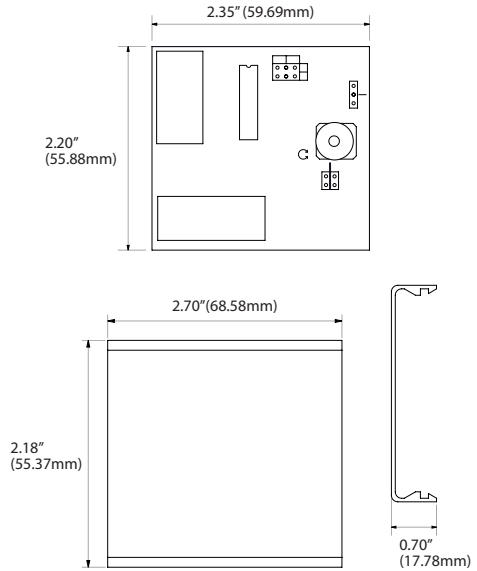

FIGURE 2: WIRING

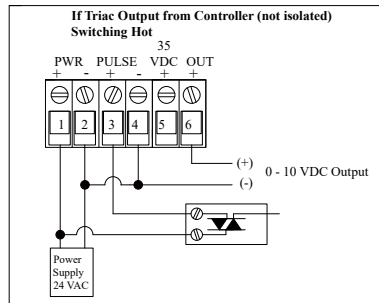
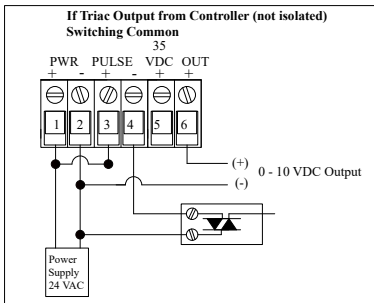
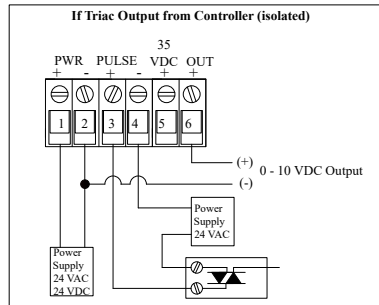
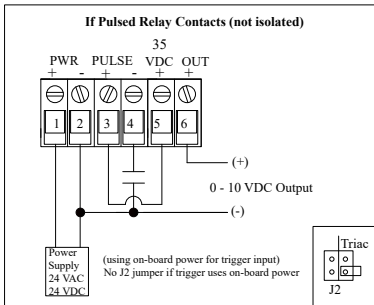
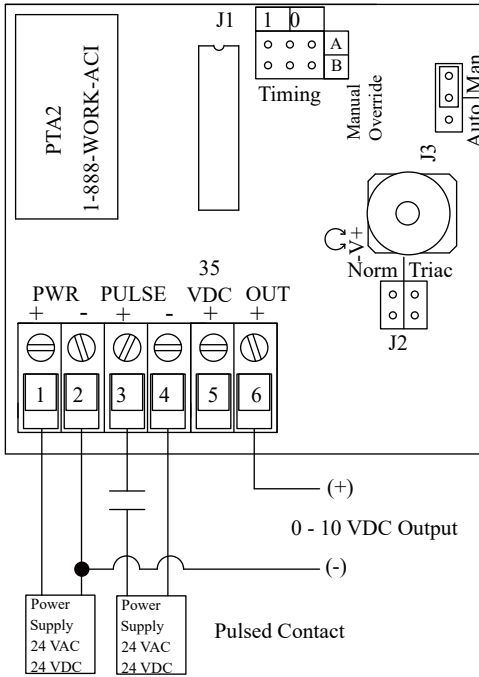
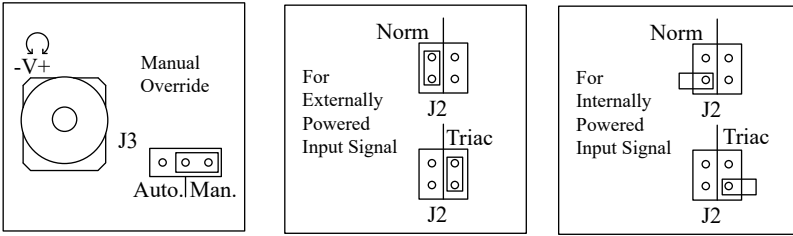

FIGURE 3: JUMPERS



SETUP

Input pulse timing range is selected by placement of jumpers on J1. Jumpers are factory set to 0.59 – 2.93 seconds. Refer to **Figure 4** for timing ranges and positions.

Set jumper J2 for normal or triac input if using external power for signal. **Note:** No jumper if using on board power. Set J3 for MAN in order to checkout connections by using manual override potentiometer. Reset J3 to AUTO for normal operation.

Explanation of Version #2, (0-10), (0-100) or (0-25.5) Second Duty Cycle mode: PTA2 accepts a continuous pulse signal command string, sampled in a 10, 100, or 25.5 second window. No pulse within a 10,100, or 25.5 second window produces minimum 0% output (0 volts). Ten second or continuous pulse produces a 100% output (10 volts).

FIGURE 4: INPUT PULSE RANGES

Input Pulse Ranges / Version 2

J1 Jumper Setting	1	0
0 - 10 Sec. Duty Cycle		
0.23 - 6 Sec.		
0 - 25.5 Sec. Duty Cycle		
0 - 100 Sec. Duty Cycle		
PTA2-3.00.Hex		

Input Pulse Ranges / Version 1

J1 Jumper Setting	1	0
0.1 - 10 Sec.		
0.02 - 5 Sec.		
0.1 - 25.5 Sec.		
0.59 - 2.93 Sec.		
0114YOE.Hex		

TROUBLE SHOOTING AND TESTING

- 1.) Apply 24 VAC/VDC to "PWR" terminal and measure voltage to confirm proper voltage.
- 2.) Check the input timing jumpers. Reset power if changes are made.
- 3.) Testing the output. Connect power. Place MAN/AUTO jumper to Manual.
0 – 10 VDC Out: With meter only connected to the OUT (+) and POWER (-), turn the manual potentiometer full left and then full right. The output should vary from 0 to 100%.

If no change is seen, contact ACI tech support.

If yes, connect load/device and meter to OUT (+) and POWER (-) terminals. Turn override pot and measure voltage.

Do the readings match the no load test?

If no, check load impedance mismatch or a possible ground loop problem and/or call ACI tech support.

If yes, voltage output is functioning properly.

DO NOT connect the output to OUT(+) and 35 VDC (+). This will damage the unit within seconds.

4.) Testing the Input.

To manually test the input apply 24 VAC/VDC to the POWER terminals. Connect your meter to the OUT (+) and POWER (-) terminals. Set the meter for voltage. Place MAN/AUTO jumper to AUTO. Connect a jumper wire to the POWER (+) only. Connect another jumper wire to PULSE (-) and POWER (-). You are now ready to simulate a timed pulse signal. For testing purposes, select 0.1 to 10 second range. Be sure to reset power to allow the PTA2 to recognize new settings. Take the free end of the jumper wire from POWER (+) and connect by holding wire to the pulse (+) terminal (be careful not to short it to POWER (-). Count to 5 seconds (or the time = to 50% of timing range) and remove. Verify the pulse LED indication. Read the output. Has the output changed? The output should be close to 50% of set output.

If no, change the TRC/NRM to the opposite setting and repeat test. Has the output changed? A voltage meter can be connected to the PULSE (+) and (-) terminals to verify voltage is present. If voltage is present and the output hasn't changed, contact ACI technical support. If the output has changed, unit is functioning properly.

Remove all test wiring after completion of testing.

PRODUCT SPECIFICATIONS

SPECIFICATIONS	
Supply Voltage:	24 VAC or 24 VDC +/-10%, 50/60 Hz
Supply Current:	135 mA maximum
Input Pulse Source:	Relay Contact Closure, Transistor, Triac, or Dry Contact to Common
Input Pulse Trigger Level:	Normal Mode = 5 to 26.4 VAC/DC Triac Mode = 9 to 26.4VAC Using Rectified DC Power Output: 21-37 VDC
Input Pulse Timing:	Version 1: 0.02 to 5.0s, 0.1 to 10.0s, 0.59 to 2.93s, 0.1 to 25.5s Version 2: 0 to 10.0s Duty Cycle Pulse (10s window), 0-25.5s Duty Cycle Pulse (25.5 sec. window), 0.023 to 6.0s
Input Pulse Impedance:	VAC = 900Ω nominal VDC = 1500Ω nominal
Voltage Output Signal (@ Impedance):	0-10 VDC @ 400Ω minimum
Output Resolution:	255 steps of resolution
Accuracy:	+/- 5%
Connections:	90° Pluggable Screw Terminal Blocks
Wire Size:	16 (1.31 mm ²) to 26 AWG (0.129 mm ²)
Terminal Block Torque Rating:	0.5 Nm (Minimum); 0.6 Nm (Maximum)
Operating Temperature Range:	35 to 120°F (1.7 to 48.9°C)
Operature Humidity Range:	10 to 95% non-condensing
Storage Temperature:	-20 to 150°F (-28.9 to 65.5°C)

WARRANTY

The PTA2 Series is covered by ACI's Two (2) Year Limited Warranty, which is located in the front of ACI'S SENSORS & TRANSMITTERS CATALOG or can be found on ACI's website: www.workaci.com.

