



Wireless Food Probe Temperature Sensor

Installation & Operations

50386_Wireless_BLE_Food_Probe

rev. 02/18/26

Overview and Identification

- NSF certified with food and dishwasher safe materials
- User adjustable settings via receiver or WAM
- Onboard memory to store readings when communication is interrupted
- Transmits to a digital Gateway or a wireless-to-analog Receiver

BAPI's Wireless Food Probe measures the temperature and transmits the data via Bluetooth Low Energy to a receiver or gateway. The food probes eliminate the need for an employee to hand record the temperatures with a thermometer for HACCP compliance. Bin clips are available to fit most food bins. The probe is designed for dishwasher or hand washing.

Because the probes are designed for wet, dusty or dirty environments, there are many additional applications including cooling towers, steam humidifiers or dusty/wet conveyor systems.



Please see BAPI's gateway or receiver instructions documents on the BAPI website to establish communication between the sensors and the gateway or the sensors and the receiver.

Gateway Instructions

www.bapihvac.com/wp-content/uploads/50387_Wireless_BLE_Gateway.pdf

Receiver Instructions

www.bapihvac.com/wp-content/uploads/50335_Wireless_BLE_Receiver_AOM.pdf

Adjustable Settings

BAPI's wireless devices have several settings that can be field adjusted to suit the needs of the installation. All settings are configured by either BAPI's cloud based Wireless Asset Monitoring (WAM) or the receiver. (See the WAM or receiver instructions available on the BAPI website for more information on adjusting the settings.)

Sample Rate/Interval – The time between when the sensor wakes up and takes a reading. The available values are 1 min or 5 min with the gateway, or 30 sec, 1 min, 3 min or 5 min with the receiver.

Transmit Rate/Interval – The time between when the sensor transmits the readings to the gateway or receiver. The available values are 1, 2, 3, 4, 5, 10, 15, 20 or 30 minutes, or 1, 6 or 12 hours with the gateway, or 1, 5, 10 or 30 minutes with the receiver.

Delta Δ Temperature – The change in temperature between a sample and the last transmission that will cause the sensor to override the transmit interval and immediately transmit the changed temperature. The available values are 0.1, 0.2, 0.3, 0.4, 0.5, 1, 2, 3, 4, 5 °F or °C with the gateway, and 1 or 3 °F or °C with the receiver.

Temperature Min/Max – The maximum or minimum temperature that will cause the sensor to override the transmit interval and immediately transmit a reading to the gateway. (Only available when using a gateway.)

Temperature Offset – Adjusts the temperature value being transmitted to match that of a calibrated reference device. The available values are $\pm 0.1, 0.2, 0.5, 1, 2, 3, 4$ or 5 °F or °C. (Only available when using a gateway.)

Associated Receiver or Gateway

RECEIVER (Wireless-to-Analog)

The wireless receiver from BAPI receives the data from one or more wireless sensors. The data is then transferred to the analog output modules and converted to an analog voltage or resistance. The receiver supports up to 32 sensors and up to 127 different analog output modules.



GATEWAY

The wireless gateway receives the data from one or more wireless sensors. The gateway then provides the data to the cloud via MQTT. The gateway also sends a confirmation signal to each sensor upon a successful reception of data. The gateway supports up to 32 sensors.



See BAPI's gateway or receiver instructions documents on the BAPI website to establish communication between the sensors and the gateway or the sensors and the receiver.

Gateway Instructions

www.bapihvac.com/wp-content/uploads/50387_Wireless_BLE_Gateway.pdf

Receiver Instructions

www.bapihvac.com/wp-content/uploads/50335_Wireless_BLE_Receiver_AOM.pdf

Initial Activation

For convenience, BAPI recommends pairing the sensor to the intended receiver or gateway prior to mounting either device. Both devices need to be powered-on to pair. See the receiver or gateway installation manual for instructions on pairing the sensor.

1. Cover Removal:

Unscrew the clear cover from the black probe bottom with the included food probe wrench (Fig 1). Do not use the stainless steel probe for leverage.



Fig. 1: Food probe clear cover removal using the included food probe wrench

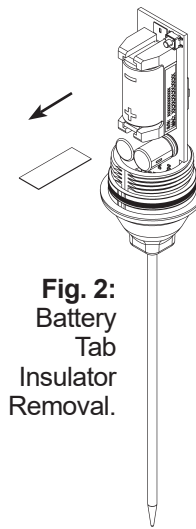

Fig. 2: Battery Tab Insulator Removal.

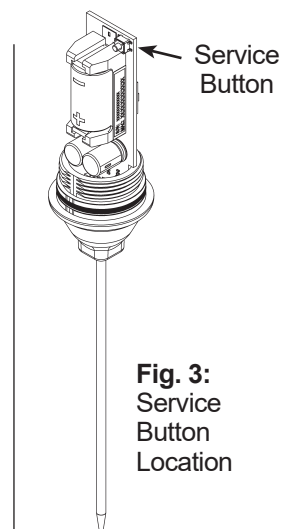

Fig. 3: Service Button Location

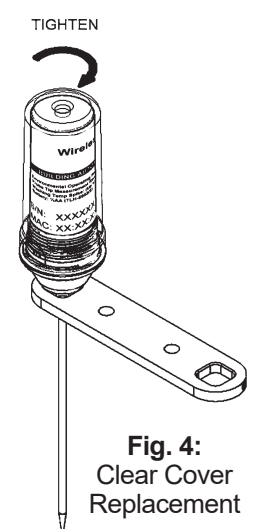

Fig. 4: Clear Cover Replacement

2. **Battery Tab Insulator Removal:** The food probe is powered by a pre-installed battery. To activate the unit, find the battery tab insulator, pull it out and discard the tab (Fig. 2). Press the "Service" button and the "Service LED" on the back side of the circuit board (Fig. 6) should flash once to confirm power.

3. **Cover Installation:** Hand-tighten the cover onto the black probe bottom until the cover is snug to the bottom (Fig 4).

Note: The cover and base are matched by serial number and MAC address.

Operation

Power the unit as described in “Initial Activation” section. Follow the gateway or receiver instructions for pairing the unit and changing the adjustable settings. (The instructions are available on the BAPI website.)

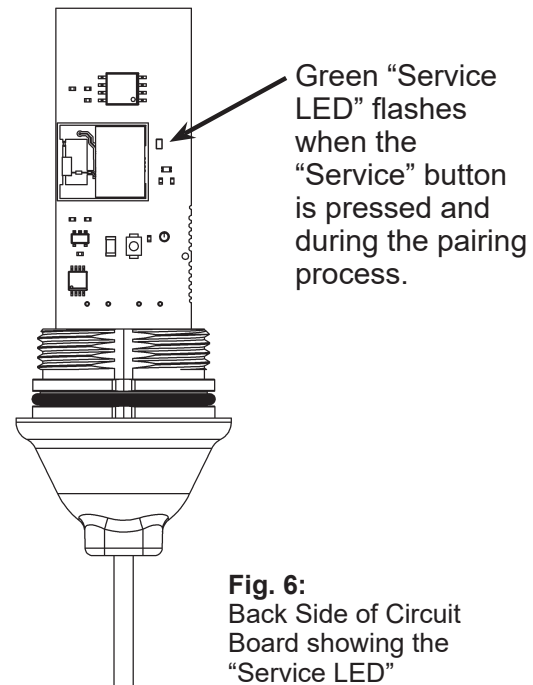
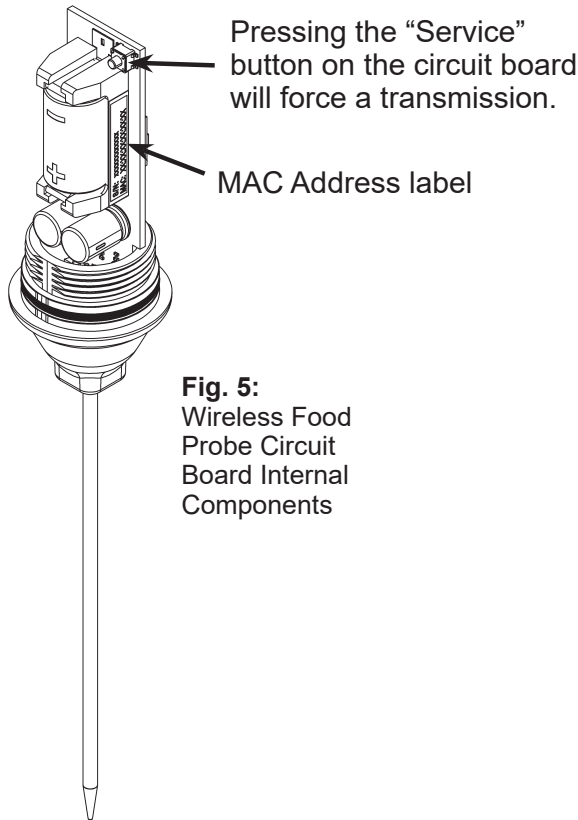

Wireless Sensor Reset

Sensors remain paired to the gateway or receiver and output modules when power is interrupted or the batteries are removed. To break the bonds between them, the sensors need to be reset. To do this, press and hold the “Service Button” on the sensor for about 30 seconds. During those 30 seconds, the green LED will be off for about 5 seconds, then flash slowly, then begin flashing rapidly. When the rapid flashing stops, the reset is complete. The sensor can now be paired to a new receiver or gateway. To re-pair to the same receiver or gateway, you must reset the receiver or gateway. Output modules that were previously paired to the sensor do not need to be re-paired.

Onboard Memory

Sensor retains up to 16,000 readings should the communication become interrupted. The sensor only stores readings from missed transmissions and only when the sensor is paired to a gateway. Once communication is re-established with the gateway, the stored readings are transmitted and then erased from the sensor. The current reading and nine previous readings are sent at each transmit interval until the sensor is caught up. Temporarily shortening the transmit interval will allow the sensor to more quickly clear any stored readings.



Wireless Food Probe Temperature Sensor

Installation & Operations

50386_Wireless_BLE_Food_Probe

rev. 02/18/26

Battery Replacement and O-Ring Inspection

Check or replace batteries and O-ring at yearly intervals.

BATTERY INSPECTION AND REMOVAL:

Remove the cover as described in the “Initial Activation” section on pg 2. Inspect the battery to be sure it is not corroded. If it is corroded or suspected of being bad, remove the battery from its holder and discard in an environmentally safe manner.

BATTERY INSTALLATION:

Place the new battery in the holder in the correct orientation (Fig. 7).

Battery Specifications: One 3.6V lithium battery (#14250 or equiv.)

O-RING INSPECTION:

Inspect the rubber O-Ring for kinks, scarring, or cracking. Replace as necessary and lubricate with any food safe lubricant. Re-install the cover as described in the “Initial Activation” section on pg 2.

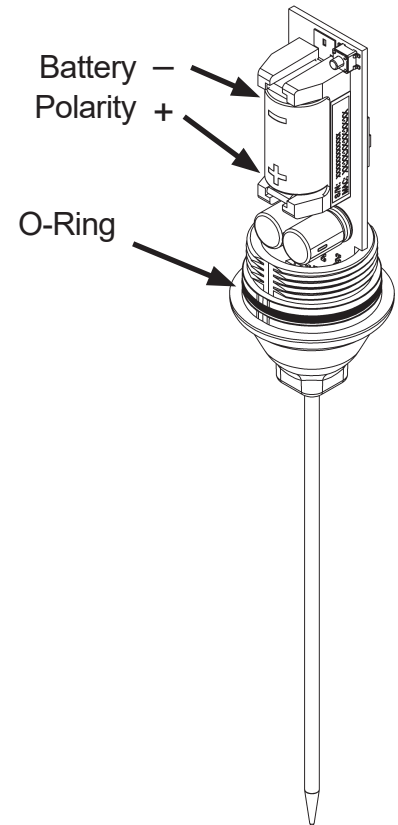

Probe Cleaning

The Wireless Food probes can be hand washed or washed in a commercial or residential dishwasher. Normal long-term use and washing will result in micro scratches which may cloud the plastic shell, but will not affect performance.

PRECAUTIONS:

1. To ensure the water seal, confirm that the cover is screwed on securely (hand tight) before each washing cycle.
2. To avoid probe failure, DO NOT twist the stainless steel probe.
3. Metal brushes or copper/steel wool should never be used on the food probe.
4. Use of sanitizers at higher than 150°F will harm the plastic case and could cause water infiltration and damage the sensor. Washing the probe in a sanitizer over 150°F will void the warranty.

HAND WASHING:

1. Follow standard food industry hand washing procedures.
2. Use a wash cloth, sponge or nylon brush to clean the metal and plastic surfaces.
3. Rinse the probe and towel dry or place in storage rack to dry.

DISHWASHER:

1. Standard dishwasher detergents and rinse agents will not harm the metal probe or plastic.
2. Typical dishwasher cycle times of less than 5 minutes at less than 165°F (74°C) are acceptable.
3. Typical rinse cycles of less than 5 min. at less than 212°F (100°C) are acceptable. However, a rinse with sanitizer should not exceed 150°F (65°C).
4. Place the food probe into the washer rack or flatware rack loosely so that all sides of the probe will be exposed to washing fluid. The probe can be in any orientation. (up/down/or on its side)



Wireless Food Probe Temperature Sensor

Installation & Operations

50386_Wireless_BLE_Food_Probe

rev. 02/18/26

Diagnostics

Possible Problems:

Sensor is not communicating with the gateway or receiver, or the transmitted values are incorrect.

Possible Solutions:

Make sure the sensor is within range of the gateway or receiver.

Verify that the green LED on the sensor circuit board flashes when the "Service" button is pressed, indicating a transmission. If it does not flash, replace the battery.

Verify that the sensor is properly paired to the gateway or receiver and analog output modules as described in the gateway or receiver instructions available on the BAPI website. Re-pair them if needed. If necessary, perform the "Wireless Sensor Reset" procedure on page 2.

Specifications

Power: One included Lithium 1/2AA Battery, 3.6V

Sensor Accuracy: (Calibrated using a NIST traceable reference)

±0.7°F (0.4°C) from 32 to 158°F (0 to 70°C)

±1.8°F (1.0°C) from 158 to 212°F (70 to 100°C)

Temperature Range: -4 to 221°F (-20 to 105°C)

Transmission Distance: Varies by application*

Environmental Operation Range:

Probe Only: -4 to 230°F (-20 to 110°C)

Entire Unit: -40 to 185°F (-40 to 85°C)

Washing Spike Temp: 212°F (100°C)

Humidity: 0 to 100% RH Condensing

Enclosure Material: Food Safe Plastic

Frequency: 2.4 GHz (Bluetooth Low Energy)

Receiver Sensitivity: -97 dBm

Probe Material: 304 SS, 1/8" (3.2mm) diameter

User Adjustable Settings:

Delta T (Temp): 0.1°F/C to 5.0°F/C

Transmit Interval: 30 sec to 12 hour***

Sample Interval: 30 sec to 5 min***

Temp Offset: ±0.1°F/C to ±5.0°F/C

Onboard Memory:

Sensor retains up to 16,000 readings should the communication become interrupted. If using a Gateway, the data is re-transmitted once communication is re-established.

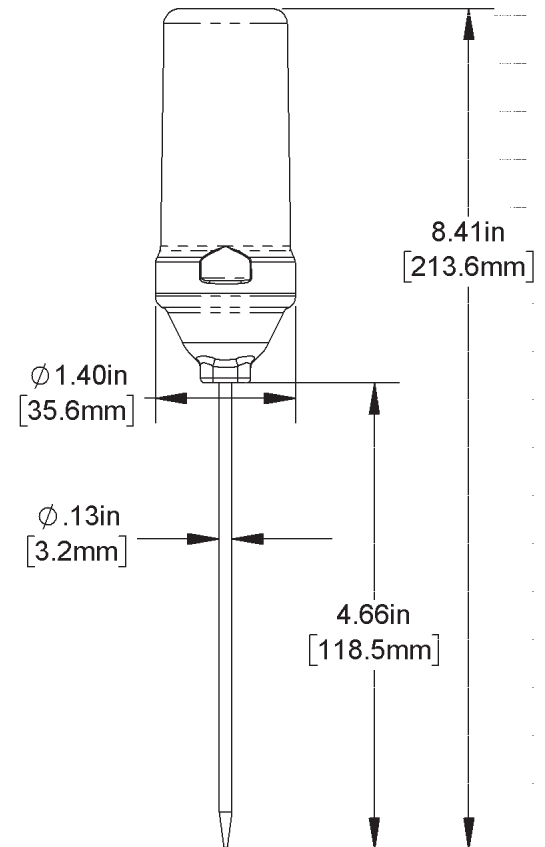

*In-building range is dependent on obstructions such as furniture and walls and the density of those materials. In wide open spaces, the distance may be greater; in dense spaces, the distance may be less.

**Actual battery life is dependent on the sensor's adjustable settings and environmental conditions.

***The available transmit intervals and sample intervals are different depending on whether the system is using a gateway or a receiver.

Food Probe Calculated Battery Life**		
Transmit Interval	Sample Rate	Estimated Life (years)
30 sec	30 sec	0.25
1 min	1 min	0.42
3 min	1 min	0.55
5 min	5 min	1.45
10 min	5 min	1.96

Specifications subject to change without notice.



Wireless Food Probe Temperature Sensor

Installation & Operations

50386_Wireless_BLE_Food_Probe

rev. 02/18/26

Agency Certifications

RoHS / Contains FCC ID: QOQGM210P / IC: 5123A-GM210 / Independent Communications Authority of South Africa

This device complies with Part 15 of the FCC Rules. Operation is subject to the following two conditions:

1. This device may not cause harmful interference, and
 2. This device must accept any interference received, including interference that may cause undesirable operation.
- Any changes or modifications not expressly approved by BAPI could void the user's authority to operate the equipment.

This device complies with Industry Canada (IC) license-exempt RSS standard(s). Operation is subject to the following two conditions.

This device may not cause interference.

This device must accept any interference, including interference that may cause undesired operation of the device.

Le présent appareil est conforme aux CNR d'Industrie Canada applicables aux appareils radio exempts de licence. L'exploitation est autorisée aux deux conditions suivantes.

L'appareil ne doit pas produire de brouillage.

L'appareil doit accepter tout brouillage radioélectrique subi, même si le brouillard est susceptible d'en compromettre le fonctionnement.



Bin Clip Dimensions

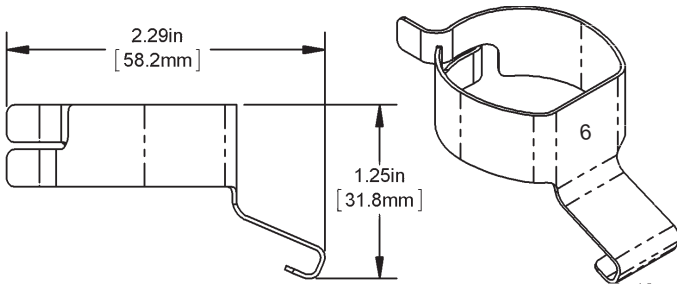

Adjustable Depth Bin Clip for Most Plastic Square Bins ("6" stamp on flat)

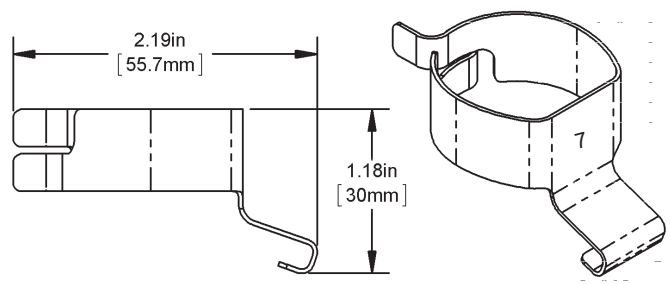

Adjustable Depth Bin Clip for Most SS Square Bins ("7" stamp on flat)

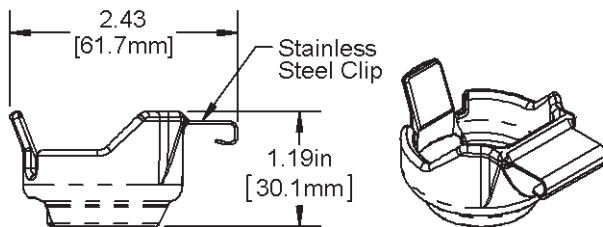

Fixed Depth Clip for Most Plastic Square Bins (Amber Plastic)

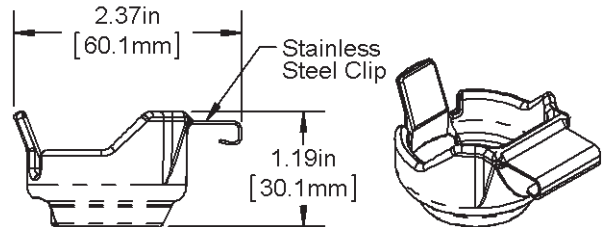

Fixed Depth Clip for Most Stainless Steel Square Bins (Black Plastic)