

### Overview and Identification

The Wireless Receiver collects the data from up to 28 wireless sensors. The data is then integrated into the BMS by a BACnet MS/TP or Modbus RTU module, a BACnet IP module, or analog output modules.

The BACnet MS/TP or Modbus RTU module converts the data for integration into the RS-485 field communication network and supports up to 28 wireless sensors.

The BACnet IP module converts the data for integration into the BMS ethernet communication network and supports up to 28 wireless sensors.

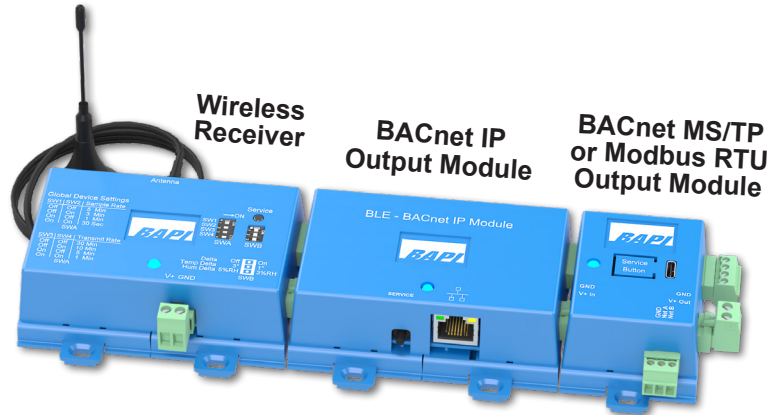

### Setup Step 1 - Pairing the Sensors to the Receiver

The installation process requires that each wireless sensor is paired to its associated receiver. The pairing process is easiest on a test bench with the sensors and receiver near each other.

1. Select the sensor that you wish to pair to the receiver and apply power to the sensor. See its manual for detailed instructions.
2. Apply power to the receiver. The blue LED on the receiver will light and remain lit.
3. Press and hold the "Service Button" on the top of the receiver until the blue LED starts to flash, then press and release the "Service Button" on the sensor (Figs 2 & 3) that you want to pair to the receiver. When the LED on the receiver returns to a solid "On" and the green "Service LED" on the sensor circuit board blinks rapidly three times, the pairing is complete. Repeat this process for all sensors.

**Note: Pairing is not needed for the output modules, only the sensors and receiver. When the BACnet MS/TP or Modbus RTU module, or the BACnet IP module are connected to the receiver, the modules will "Auto-Discover" all the sensors that are paired with the receiver.**

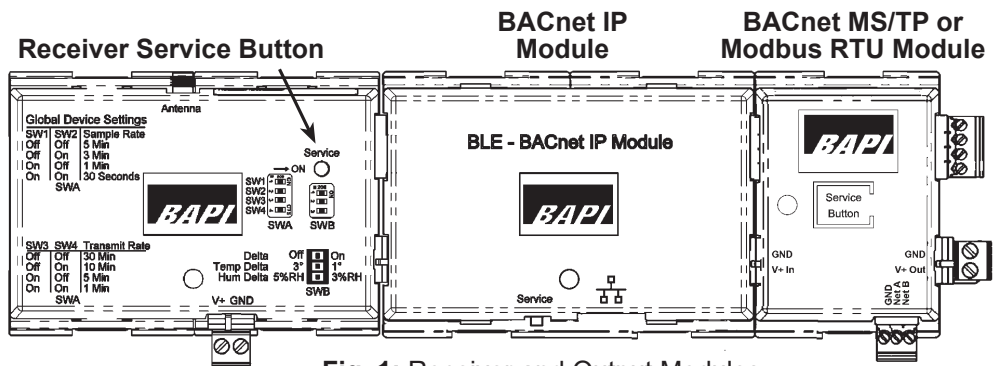

Fig. 1: Receiver and Output Modules

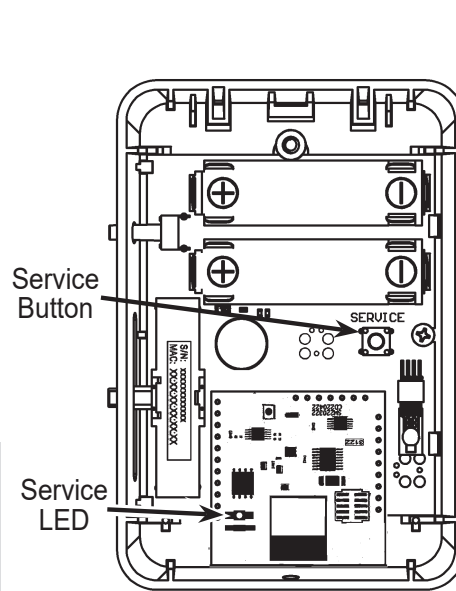

Fig. 2: BAPI-Stat "Quantum" Sensor Service Button and LED

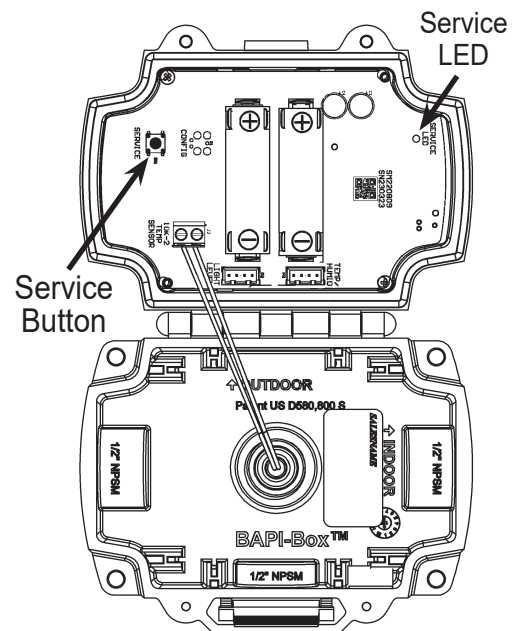

Fig. 3: BAPI-Box Sensor Service Button and LED

### Setup Step 2 - Mounting and Locating of Antenna

The antenna has a magnetic base for mounting. Although the receiver may be located inside a metal enclosure, the antenna must be outside the enclosure. There must be a non-metallic line of sight from all the sensors to the antenna. Acceptable line of sight includes walls made from wood, sheet rock or plaster with non-metallic lath. The orientation of the antenna (horizontal or vertical) will also affect the performance and varies by application.

Mounting the antenna on a metal surface will cut off reception from behind the surface. Frosted windows may block reception too. A wooden or plastic furring strip attached to a ceiling beam makes a great mount. The antenna may be hung from any ceiling fixture using fiber or plastic twine. Do not use wire to hang, and do not use perforated metal strapping, commonly called plumbers tape.

### Setup Step 3 - Mounting of Receiver and Output Modules

The receiver and output modules can be snaptrack, DIN Rail or surface mounted. Each receiver can accommodate up to 127 modules. Start with the receiver at the far left, then securely attach each output module to the right.

Push in the blue mounting tabs to mount in 2.75" snaptrack (Fig 4). Push out the mounting tabs for DIN Rail (Fig 5). Catch the EZ mount hook on the edge of the DIN rail (Fig 6) and rotate into place. Push out the mounting tabs for surface mounting using the four supplied screws, one in each tab (Fig 7).

If your output modules cannot fit in one straight line because of limited space, then mount a second string of modules above or below. Connect wires from the right side of the first string of modules to the left side of the second string of modules.

This configuration requires one or more Pluggable Terminal Block Connector Kits (BA/AOM-CONN) for the extra wire terminations on the left and right side of the output modules. Each kit includes one set of 4 connectors.

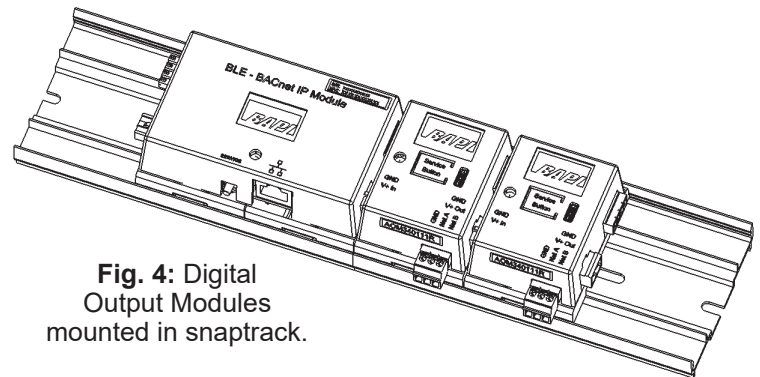
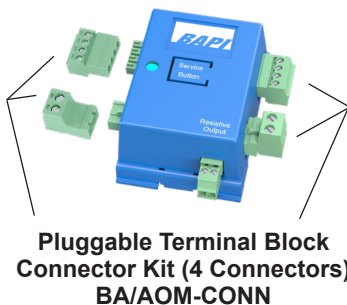

Fig. 4: Digital Output Modules mounted in snaptrack.

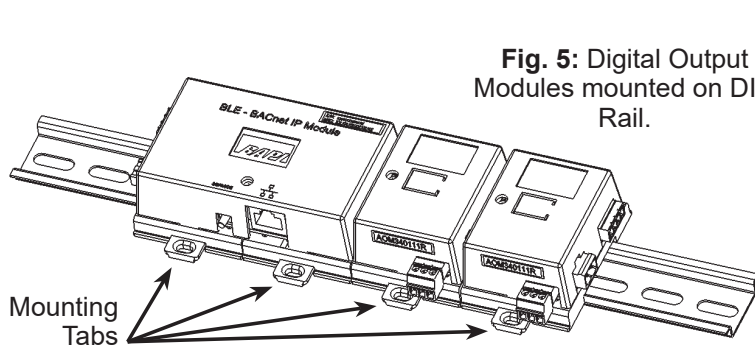

Fig. 5: Digital Output Modules mounted on DIN Rail.

Fig. 6: Catch the EZ mount hook on the edge of the DIN Rail, then rotate into place.

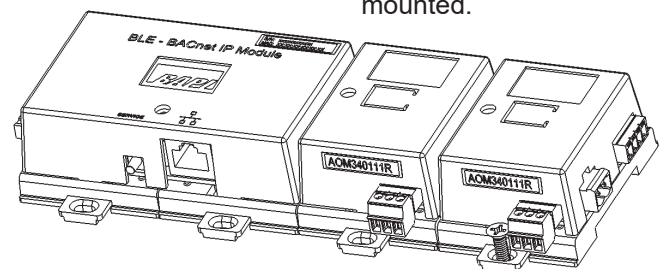
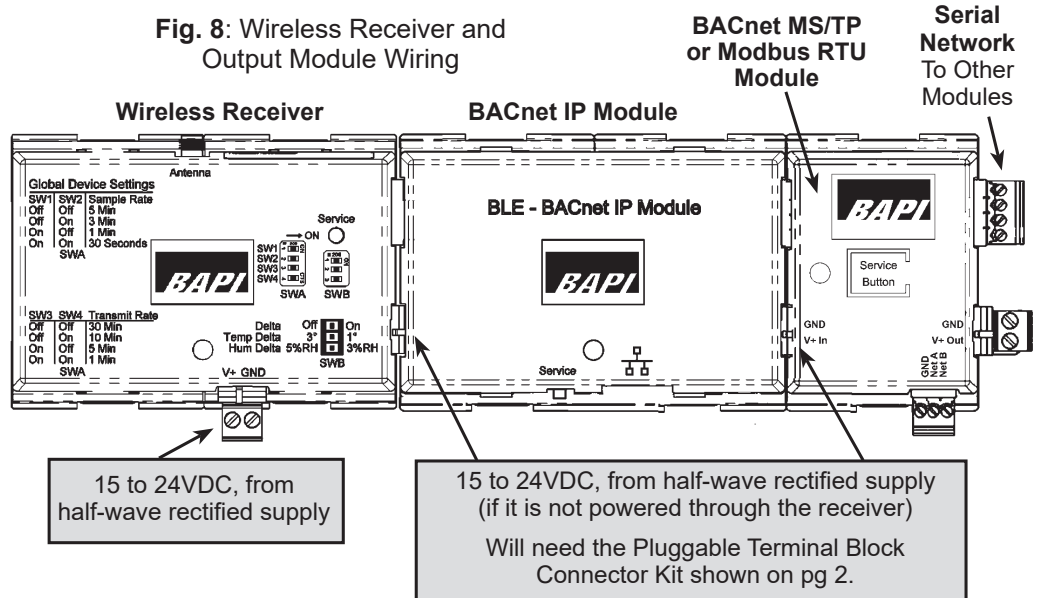

Fig. 7: Digital Output Modules surface mounted.

### Setup Step 4 - Termination

The receiver and output modules are pluggable and can be connected in an attached string as shown at right. The power for the output modules is supplied by the receiver in this configuration. If the modules are powered separately rather than from the receiver (as shown below), then they must have 15 to 24VDC. Be sure that you supply enough power for all the devices on the bus.

**Note:** The receiver can accommodate up to 127 different output modules; however, only 10 modules can be powered directly from the receiver. To add additional modules, follow the "Extending the Serial Network" directions on pg 4.



### Setup Step 5 - Receiver Switch Settings

All sensor settings are controlled and adjusted by the receiver to suit the needs of the installation. These are adjusted via the DIP switches on the top of the receiver. These are the settings for **ALL OF THE SENSORS** that are paired to that receiver.

**Sample Rate/Interval** – The time between when the sensor wakes up and takes a reading. The available values 30 sec, 1 min, 3 min or 5 min.

**Transmit Rate/Interval** – The time between when the sensor transmits the readings to the receiver. The available values are 1, 5, 10 or 30 minutes.

**Temperature Delta  $\Delta$**  – The change in temperature between a sample and the last transmission that will cause the sensor to override the transmit interval and immediately transmit all values to the receiver. The available values are 1 or 3 °F or °C.

**Humidity Delta  $\Delta$**  – The change in humidity between a sample and the last transmission that will cause the sensor to override the transmit interval and immediately transmit all values to the receiver. The available values are 3 or 5 %RH.

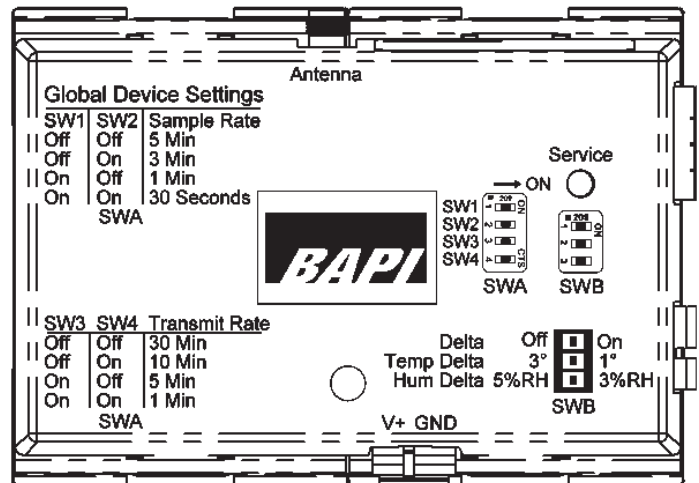

Fig. 9: Wireless Receiver Adjustment Switches

### Setup Step 6 - Configuration Utilities

The Configuration Utilities for the output modules are available for download on the BAPI website at [www.bapihvac.com](http://www.bapihvac.com). Go to the product page for the module and click on the provided link to access the utilities.

### Extending the Serial Network Between the Receiver and Modules or Powering Additional Groups of Modules

The output modules may be mounted up to 4,000 feet (1,200 meters) away from the receiver using the configuration shown in Fig 11. The total length of all the shielded, twisted pair cables shown in Fig. 11 is 4,000 feet (1,200 meters). If the distance from the receiver to the group of output modules is greater than 100 feet (30 meters), provide a separate power supply or voltage converter (such as BAPI's VC350A EZ) for that group of output modules.

Also, each receiver can accommodate up to 127 different output modules; however, only 10 modules can be powered directly from the receiver. Follow the directions shown here to add additional modules.

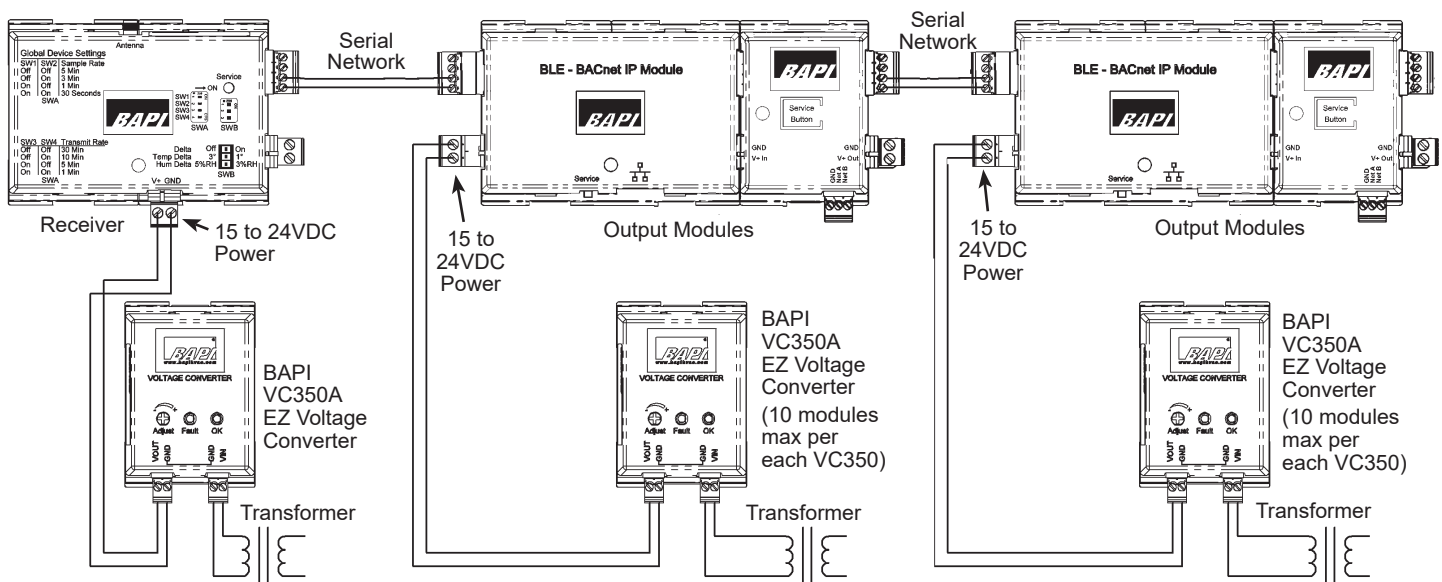
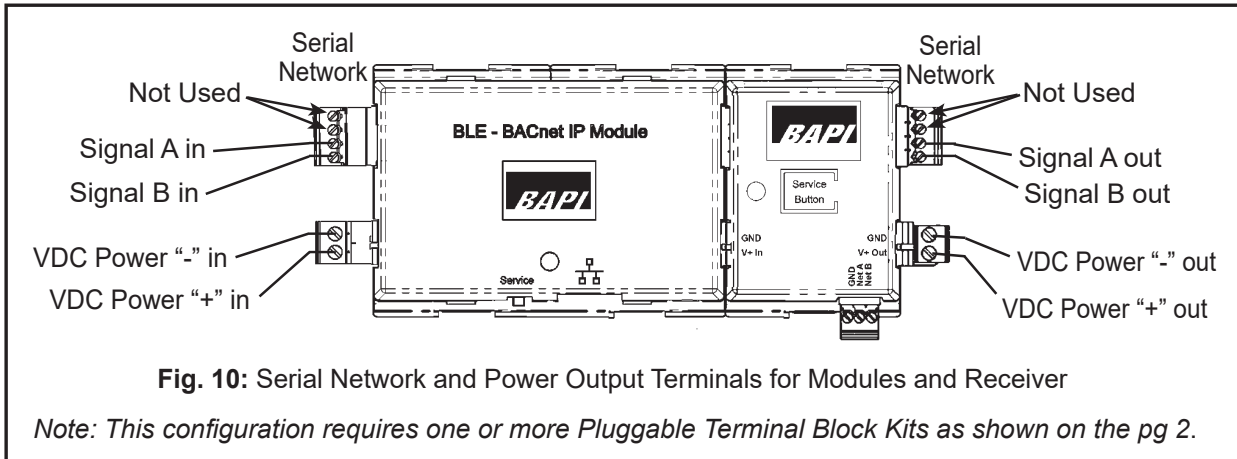

**Fig. 11:** Extended Serial Network between the Receiver and the Digital Output Modules



# Wireless Receiver and Digital Output Modules

Installation, Operation and Configuration Instructions

54001\_BACNET IP\_Module\_Ins\_and\_Setup

rev. 09/15/25

## Resetting a Sensor, Receiver or Output Module

Sensors, receivers and output modules remain paired to each other when power is interrupted or the batteries are removed. To break the bonds between them, the units need to be reset as described below:

### TO RESET A SENSOR:

Press and hold the "Service Button" on the sensor for about 30 seconds. During those 30 seconds, the green LED will be off for about 5 seconds, then flash slowly, then begin flashing rapidly. When the rapid flashing stops, the reset is complete. The sensor can now be paired to a new receiver. Sensors that were previously discovered by the Digital Output Modules will not need to be rediscovered.

### TO RESET A DIGITAL OUTPUT MODULE:

Press and hold the "Service Button" on the top of the unit for 10 seconds – the LED will go solid for 2 seconds and all the BACnet, Ethernet, and Serial Settings will be erased. Holding down the service button for an additional 20 seconds, the LED will go solid for 4 seconds and all the sensor objects will be erased.

### TO RESET A RECEIVER:

Press and hold the "Service Button" on the sensor for about 20 seconds. During those 20 seconds, the blue LED will flash slowly, then begin flashing rapidly. When the rapid flashing stops and returns to solid blue, the reset is complete. The unit can now be re-paired to the output modules. **Caution! Resetting the receiver will break the bonds between the receiver and all sensors. The sensors will need to be re-paired with the receiver.**

## Default Status When Wireless Transmission is Interrupted

If an output module does not receive data from a paired sensor for 35 minutes, an error state will happen to indicate this. If this happens, the individual output modules will react as described below. Once a transmission is received, the output modules will revert to normal operation in 5 seconds or less.

**BACnet IP Module:** Each sensor object has an "Event State" property which will turn from a Normal state to a Fault state, and there is a "Reliability" property which will indicate a "Communication Failure"

**BACnet MS/TP or Modbus RTU Module:** When the module is in Modbus mode, there is an error register for each sensor object and the value of the register will become 1 when timed out. When the module is in BACnet mode, each sensor object has an "Event State" property which will turn from a Normal state to a Fault state, and there is a "Reliability" property which will indicate a "Communication Failure".

## Wireless System Diagnostics

### Possible Problems:

The reading from the sensor is incorrect or at its low limit:

### Possible Solutions:

- Press the sensor's "Service" button (as described in the "Pairing the Sensors to the Receiver" section on pg 1) and verify that the green LED on the sensor circuit board flashes. If not, replace the batteries.
- Press the sensor's "Service" button and verify that the LEDs on the receiver and the output module blink. If they do not, try resetting then re-pairing the sensor to the receiver.
- Check for proper wiring and connections from the receiver to the output modules.

The LED on the output module is blinking rapidly:

- This only occurs on a hardware error. Try power cycling the device or contact BAPI for additional assistance.

### Specifications

#### Receiver

**Supply Power:** 15 to 24 VDC (from half-wave rectified supply)

**Power Consumption:** 30 mA @ 24 VDC

**Safety Current:** 200 mA

**Capacity/Unit:**

Up to 28 sensors | Up to 127 different output modules

**Reception Distance:** Varies by application\*

**Frequency:** 2.4 GHz (Bluetooth Low Energy)

**Bus Cable Distance:** 4,000 feet (1,200 meters)

**Environmental Operation Range:**

Temp: 32 to 140°F (0 to 60°C) | Humidity: 5 to 95% RH non-condensing

**Enclosure Material & Rating:** ABS Plastic, UL94 V-0 (Indoor use only)

**Agency:** RoHS / Contains FCC ID: QOQGM210P / IC: 5123A-GM210P

\*In-building range is dependent on obstructions such as furniture and walls and the density of those materials. In wide open spaces, the distance may be greater; in dense spaces, the distance may be less.

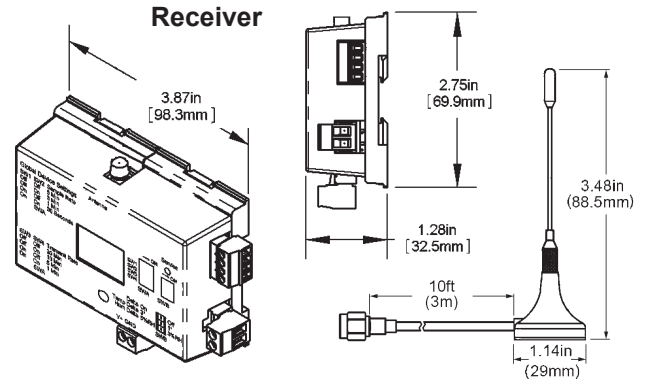

#### BACnet IP Module

**Supply Power:** 15 to 24 VDC (from half-wave rectified supply), or powered through the receiver if connected.

**Note on Power:** If powering the module separately, only use a power supply with a fuse or current limiting feature. The exact type of supply (fused DC, current-limited, or a wireless receiver with protection) is up to the installer.

**Power Consumption:** 40 mA max @ 24 VDC

**Lost Communication Timeout:** 35 minutes

**Ethernet Standard:** 10/100BASE-TX

**Environmental Operation Range:**

Temp: 32 to 140°F (0 to 60°C)

Humidity: 5 to 95% RH non-condensing

**Encl. Material & Rating:** ABS Plastic, UL94 V-0 (Indoor use only)

**Agency:** RoHS (CE pending)

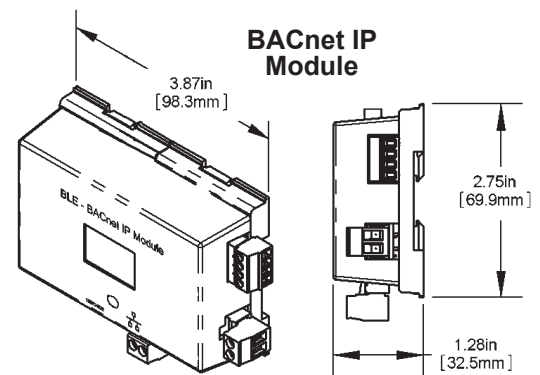

#### BACnet MS/TP or Modbus RTU Module

**Supply Power:** 15 to 24 VDC (from half-wave rectified supply), or powered through the receiver if connected.

**Note on Power:** If powering the module separately, only use a power supply with a fuse or current limiting feature. The exact type of supply (fused DC, current-limited, or a wireless receiver with protection) is up to the installer.

**Power Consumption:** 40 mA max @ 24 VDC

**Lost Communication Timeout:** 35 minutes

**Bus Cable Distance:** 4,000 feet (1,200 meters)

**Environmental Operation Range:**

Temp: 32 to 140°F (0 to 60°C) | Humidity: 5 to 95% RH non-condensing

**Encl. Material & Rating:** ABS Plastic, UL94 V-0 (Indoor use only)

**Agency:** RoHS (CE pending)

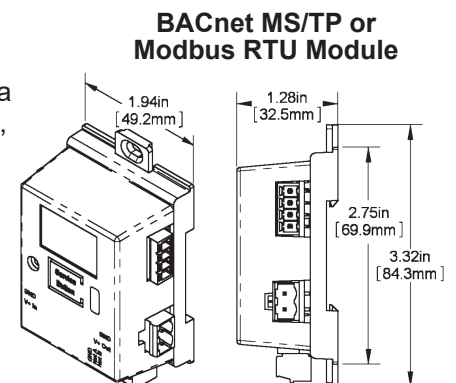

Specifications subject to change without notice.



# Wireless Receiver and Digital Output Modules

*Installation, Operation and Configuration Instructions*

54001\_BACNET IP\_Module\_Ins\_and\_Setup

rev. 09/15/25

## Agency Certifications

RoHS / Contains FCC ID: QOQGM210P / IC: 5123A-GM210 / Independent Communications Authority of South Africa

This device complies with Part 15 of the FCC Rules. Operation is subject to the following two conditions:

1. This device may not cause harmful interference, and
  2. This device must accept any interference received, including interference that may cause undesirable operation.
- Any changes or modifications not expressly approved by BAPI could void the user's authority to operate the equipment.

This device complies with Industry Canada (IC) license-exempt RSS standard(s). Operation is subject to the following two conditions.

This device may not cause interference.

This device must accept any interference, including interference that may cause undesired operation of the device.

Le présent appareil est conforme aux CNR d'Industrie Canada applicables aux appareils radio exempts de licence. L'exploitation est autorisée aux deux conditions suivantes.

L'appareil ne doit pas produire de brouillage.

L'appareil doit accepter tout brouillage radioélectrique subi, même si le brouillard est susceptible d'en compromettre le fonctionnement.



### BACnet MS/TP or Modbus RTU Module Configuration Utility

Before configuring the module, all of the sensors in your system need to be paired with the receiver as described earlier in this instructions document. The module also needs to be connected with the receiver long enough that it has received at least one transmission from each of the sensors.

#### Module in BACnet MS/TP Mode

To configure the device, follow the steps below.

1. Open a browser on your computer and go to the BACnet MS/TP or Modbus RTU Module product page on the BAPI website. Download the .zip file and extract the contents.
2. Double click the “BAPI.DeviceConfiguration.exe” file to run the utility.
3. Connect a USB cable between your computer and the USB-C connector on the module. The data for the device settings will populate the Device Utility Information Window (Fig 1). **Note:** The module does not need to be powered for the configuration. The USB-C cable will provide the necessary power.
4. Edit the values in the Serial Settings section of the Device Configuration Window for your application. Select BACnet as the Output Protocol and the Protocol Settings section below the Serial Settings will be shown.
5. Click Advanced Options to open the Advanced Options window (Fig 2). Click the Select Object Dropdown to choose one of the available objects for that sensor (Fig 3). Edit the Object Name and Change of Value Delta fields if desired. Click Submit to save your changes to the sensor before selecting the next sensor. Select Delete option to remove any objects.
6. Click Submit to save your changes to the sensor before selecting the next object.
7. When completed with the last object, click Submit and then Close to return to the main window.
8. If any settings are changed, please restart the device by clicking on the Restart Device button at the bottom of the configuration tool, which will perform a power cycle operation and apply the new settings.
9. The configuration is now complete so you can disconnect the USB cable.

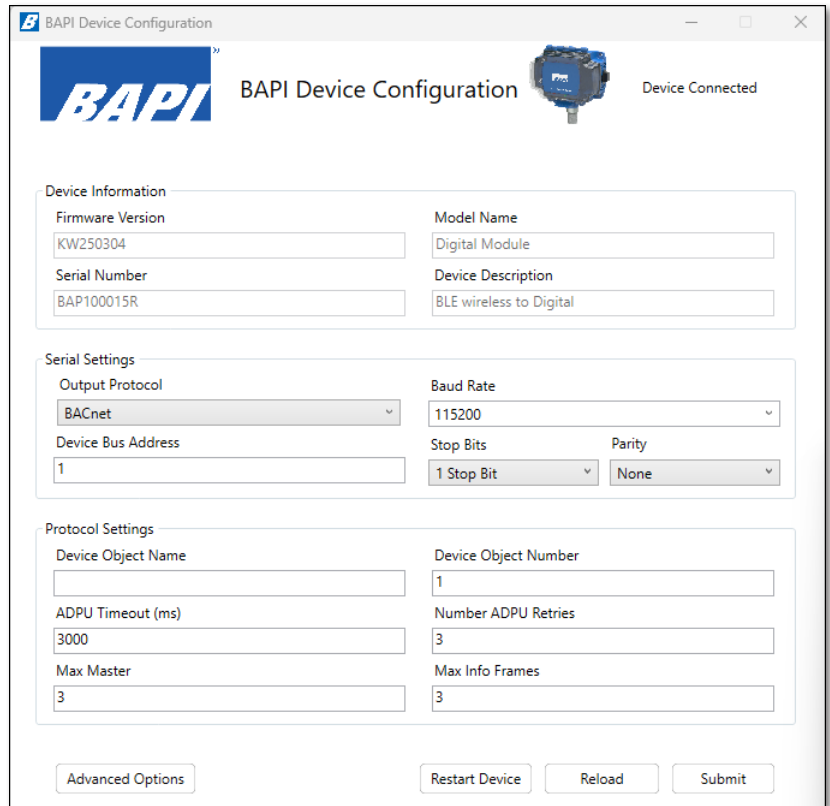

Fig. 1: Device Configuration Window in BACnet Protocol

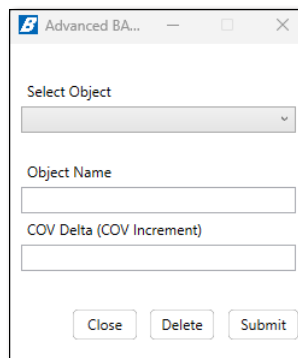

Fig. 2: Advanced Options Window

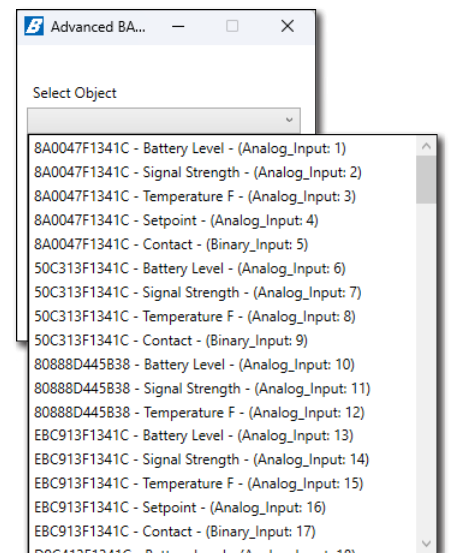

Fig. 3: Select Object Dropdown



# Wireless Receiver and Digital Output Modules

Installation, Operation and Configuration Instructions

54001\_BACNET IP\_Module\_Ins\_and\_Setup

rev. 09/15/25

## BACnet MS/TP or Modbus RTU Module Configuration Utility continued...

Before configuring the module, all of the sensors in your system need to be paired with the receiver as described as described earlier in this instructions document. The module also needs to be connected with the receiver long enough that it has received at least one transmission from each of the sensors.

### Module in Modbus RTU Mode

To configure the utility, follow the steps below.

1. Open a browser on your computer and go to the BACnet MS/TP or Modbus RTU Module product page on the BAPI website. Download the .zip file and extract the contents.
2. Double click the “BAPI.DeviceConfiguration.exe” file to run the utility.
3. Connect a USB cable between your computer and the USB-C connector on the module. The data for the device settings will populate the Device Configuration Window (Fig 4). **Note:** The module does not need to be powered for the configuration. The USB-C cable will provide the necessary power.
4. Edit the values in the Serial Settings section of the Device Utility Information Window for your application. Select Modbus as the Output Protocol and the Download Modbus Map button appears.
5. When using Modbus RTU as the output protocol, it is essential to download the Modbus map. After downloading, open the accompanying Modbus map spreadsheet (Fig 5). You can rename the file as desired or keep the original name. Once you have saved the file, all the necessary information will be readily available for updating the settings in your controller and BMS.
6. If any settings are changed, please restart the device by clicking on the Restart Device button at the bottom of the configuration tool, which will perform a power cycle operation and apply the new settings.
7. You can now disconnect the USB cable.

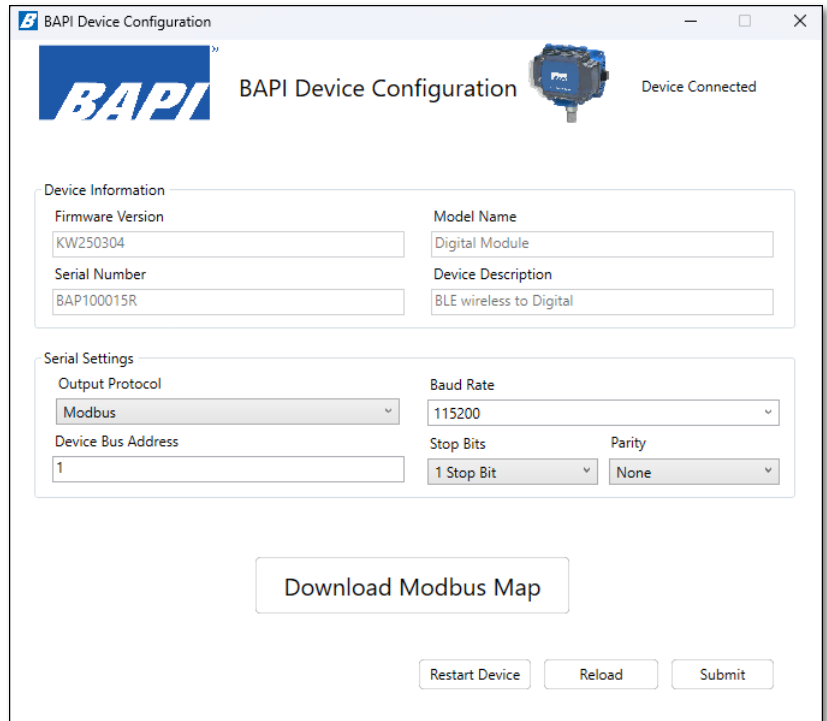

Fig. 4: Device Configuration Window in Modbus Protocol

MODBUS MAP	LOCATION	DATATYPE	VALUE	NOTES
Firmware Version	0x4000	uint16[8]	KW250304	The firmware version of the device.
Serial Number	0x4008	uint16[10]	BAP100015R	The serial number of the digital output module device.
Baud Rate	0x4070	uint32	115200	The baud rate of the RS-485 port.
Stop Bits	0x4073	uint16	0	The number of stop bits for the RS-485 port.
Parity	0x4074	uint16	0	The parity setting for the RS-485 port.
Object 0 Input Type	0x4548	uint16	1	This object slot corresponds to the Battery Level sensor on the device.
Object 0 Device Serial Number	0x454E	uint16[12]	56	This object slot corresponds to the device with the serial number 8A0047F1341C
Object 0 Input Range Minimum	0x4566	float32	2	The min raw value that the sensor should be able to reach under normal operation.
Object 0 Input Range Maximum	0x4568	float32	4	The max raw value that the sensor should be able to reach under normal operation.
Object 1 Input Type	0x459E	uint16	2	This object slot corresponds to the Signal Strength sensor on the device.
Object 1 Device Serial Number	0x45A4	uint16[12]	56	This object slot corresponds to the device with the serial number 8A0047F1341C
Object 1 Input Range Minimum	0x45BC	float32	-100	The min raw value that the sensor should be able to reach under normal operation.
Object 1 Input Range Maximum	0x45BE	float32	0	The max raw value that the sensor should be able to reach under normal operation.
Object 2 Input Type	0x45FA	uint16	5	This object slot corresponds to the Temperature F sensor on the device.
Object 2 Device Serial Number	0x45F2	uint16[12]	56	This object slot corresponds to the device with the serial number 8A0047F1341C
Object 2 Input Range Minimum	0x4612	float32	-40	The min raw value that the sensor should be able to reach under normal operation.
Object 2 Input Range Maximum	0x4614	float32	158	The max raw value that the sensor should be able to reach under normal operation.
Object 3 Input Type	0x464A	uint16	17	This object slot corresponds to the Setpoint sensor on the device.
Object 3 Device Serial Number	0x4650	uint16[12]	56	This object slot corresponds to the device with the serial number 8A0047F1341C
Object 3 Input Range Minimum	0x4668	float32	0	The min raw value that the sensor should be able to reach under normal operation.
Object 3 Input Range Maximum	0x466A	float32	100	The max raw value that the sensor should be able to reach under normal operation.
Object 4 Input Type	0x46A0	uint16	18	This object slot corresponds to the Contact sensor on the device.
Object 4 Device Serial Number	0x46A6	uint16[12]	56	This object slot corresponds to the device with the serial number 8A0047F1341C
Object 4 Input Range Minimum	0x46BE	float32	0	The min raw value that the sensor should be able to reach under normal operation.
Object 4 Input Range Maximum	0x46C0	float32	1	The max raw value that the sensor should be able to reach under normal operation.
Object 5 Input Type	0x46F6	uint16	1	This object slot corresponds to the Battery Level sensor on the device.
Object 5 Device Serial Number	0x46FC	uint16[12]	53	This object slot corresponds to the device with the serial number 50C313F1341C
Object 5 Input Range Minimum	0x4714	float32	2	The min raw value that the sensor should be able to reach under normal operation.
Object 5 Input Range Maximum	0x4716	float32	4	The max raw value that the sensor should be able to reach under normal operation.
Object 6 Input Type	0x474C	uint16	2	This object slot corresponds to the Signal Strength sensor on the device.
Object 6 Device Serial Number	0x4752	uint16[12]	53	This object slot corresponds to the device with the serial number 50C313F1341C
Object 6 Input Range Minimum	0x476A	float32	-100	The min raw value that the sensor should be able to reach under normal operation.
Object 6 Input Range Maximum	0x476C	float32	0	The max raw value that the sensor should be able to reach under normal operation.
Object 7 Input Type	0x47A2	uint16	5	This object slot corresponds to the Temperature F sensor on the device.
Object 7 Device Serial Number	0x47A8	uint16[12]	53	This object slot corresponds to the device with the serial number 50C313F1341C
Object 7 Input Range Minimum	0x47C0	float32	-40	The min raw value that the sensor should be able to reach under normal operation.
Object 7 Input Range Maximum	0x47C2	float32	158	The max raw value that the sensor should be able to reach under normal operation.
Object 8 Input Type	0x47F8	uint16	18	This object slot corresponds to the Contact sensor on the device.
Object 8 Device Serial Number	0x47FE	uint16[12]	53	This object slot corresponds to the device with the serial number 50C313F1341C
Object 8 Input Range Minimum	0x4816	float32	0	The min raw value that the sensor should be able to reach under normal operation.
Object 8 Input Range Maximum	0x4818	float32	1	The max raw value that the sensor should be able to reach under normal operation.

Fig. 5: Modbus Map Spreadsheet

### BACnet IP Module Configuration Utility:

To configure the module, follow the steps below.

1. Power the module using the BLE Receiver.
2. Connect the module using the Ethernet port to a network with a DHCP server. The DHCP server will assign a Private IP address to the module.
3. Use a BACnet discovery tool or the one included in a BMS controller to find the device's IP address. The factory default for the BACnet interface is running on UDP port 47808. Open a web browser and enter the IP address to access the device's web interface. You will need to log in with the following default credentials:

Username: admin

Password: admin

4. Upon login, please make all the necessary changes to network settings (Fig 6), device settings (Fig 7), object settings (Fig 8) and user details.
5. If you want to reset the module please press and hold the "Service Button" on the top of the unit for 10 seconds, the LED will go solid for 2 seconds and all device settings will be erased. Holding down the "Service Button" for additional 20 seconds, the LED will go solid for 4 seconds and all the sensor objects will be erased.

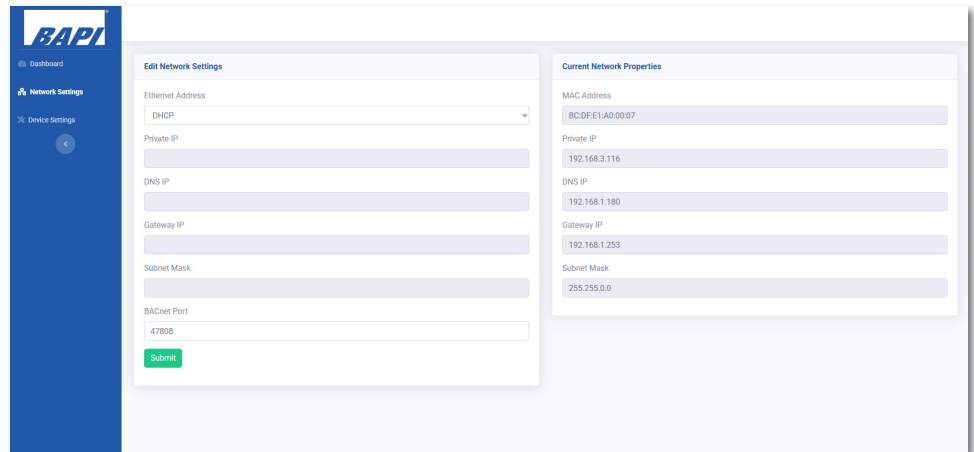

Fig. 6: Network Settings Window

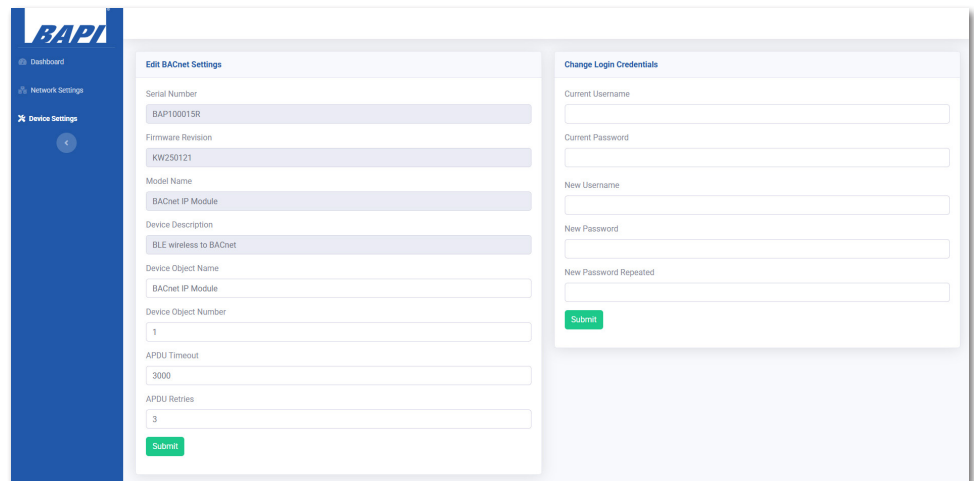
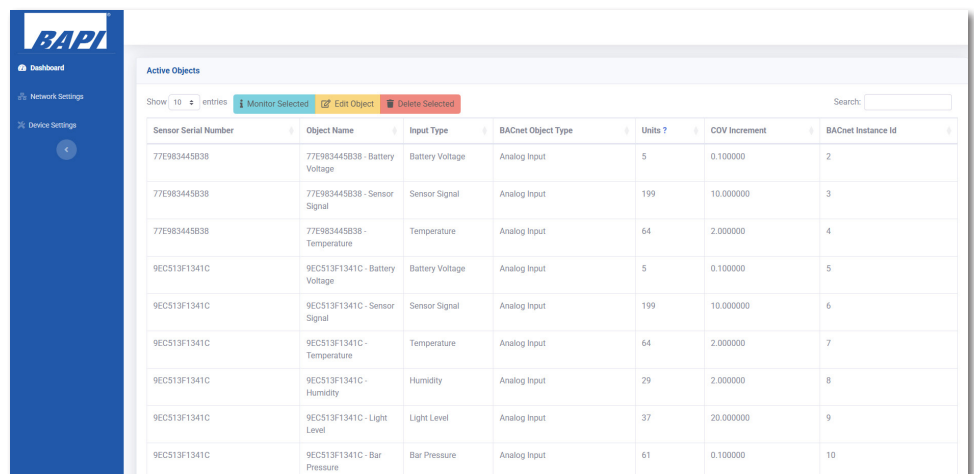

Fig. 7: Device Settings Window



Sensor Serial Number	Object Name	Input Type	BACnet Object Type	Units ?	COV Increment	BACnet Instance Id
77E983445B38	77E983445B38 - Battery Voltage	Battery Voltage	Analog Input	5	0.100000	2
77E983445B38	77E983445B38 - Sensor Signal	Sensor Signal	Analog Input	199	10.000000	3
77E983445B38	77E983445B38 - Temperature	Temperature	Analog Input	64	2.000000	4
9EC513F1341C	9EC513F1341C - Battery Voltage	Battery Voltage	Analog Input	5	0.100000	5
9EC513F1341C	9EC513F1341C - Sensor Signal	Sensor Signal	Analog Input	199	10.000000	6
9EC513F1341C	9EC513F1341C - Temperature	Temperature	Analog Input	64	2.000000	7
9EC513F1341C	9EC513F1341C - Humidity	Humidity	Analog Input	29	2.000000	8
9EC513F1341C	9EC513F1341C - Light Level	Light Level	Analog Input	37	20.000000	9
9EC513F1341C	9EC513F1341C - Bar Pressure	Bar Pressure	Analog Input	61	0.100000	10

Fig. 8: Object Settings Window