

Cloud capable and communicating Non Fail-Safe damper actuator for controlling dampers in typical commercial HVAC applications.

- Torque motor 180 in-lb [20 Nm]
- Nominal voltage AC/DC 24 V
- Control Modulating, Communicative, Hybrid, Cloud
- Conversion of sensor signals
- Ethernet 10/100 Mbit/s, TCP/IP, integrated web server
- Communication via BACnet IP, Modbus TCP and Cloud



Picture may differ from product



5-year warranty



Technical data

| | | |
|-------------------------------|------------------------------------|------------------------------------------------------------------------------------|
| Electrical data | Nominal voltage | AC/DC 24 V |
| | Nominal voltage frequency | 50/60 Hz |
| | Nominal voltage range | AC 19.2...28.8 V / DC 21.6...28.8 V |
| | Power consumption in operation | 6 W |
| | Power consumption in rest position | 3 W |
| | Transformer sizing | 8 VA |
| | Connection supply/control | cable 3 ft. [1 m], 6x 0.5 mm ² |
| | Parallel operation | Yes (note the performance data) |
| | Electrical Connection | 18 AWG appliance cable, 1/2" NPT conduit connector plug and RJ45 socket (Ethernet) |
| | Overload Protection | electronic throughout 0...95° rotation |
| Data bus communication | Communicative control | Cloud BACnet/IP Modbus TCP |
| | Number of nodes | BACnet / Modbus see interface description |
| Functional data | Torque motor | 180 in-lb [20 Nm] |
| | Operating range Y | 2...10 V |
| | Operating range Y note | Hybrid via 2...10 V |
| | Input impedance | 34 kΩ |
| | Operating range Y variable | 0.5...10 V |
| | Position feedback U | 2...10 V |
| | Position feedback U note | Max. 0.5 mA |
| | Position feedback U variable | VDC variable |
| | Position accuracy | ±5% |
| | Direction of motion motor | selectable with switch 0/1 |
| | Manual override | external push button |
| | Angle of rotation | 95° |
| | Angle of rotation note | adjustable with mechanical stop |
| | Running Time (Motor) | 150 s / 90° |
| Running time motor variable | 70...220 s | |

Technical data

| | | |
|------------------------|----------------------------------------|---------------------------------------------------------------------------------------------|
| Functional data | Sound power level, motor | 45 dB(A) |
| | Adaptation Setting Range | manual |
| | Position indication | Mechanical, pluggable |
| Safety data | Protection class IEC/EN | III, Safety Extra-Low Voltage (SELV) |
| | Power source UL | Class 2 Supply |
| | Degree of protection IEC/EN | IP54 when using protective cap or protective grommet for RJ45 socket |
| | Degree of protection NEMA/UL | NEMA 1 |
| | Housing | UL Enclosure Type 1 |
| | EMC | CE according to 2014/30/EU |
| | Agency Listing | cULus acc. to UL60730-1A/-2-14, CAN/CSA E60730-1:02 CE acc. to 2014/30/EU and 2014/35/EU |
| | Quality Standard | ISO 9001 |
| | UL 2043 Compliant | Suitable for use in air plenums per Section 300.22(C) of the NEC and Section 602 of the IMC |
| | Type of action | Type 1 |
| | Rated impulse voltage supply / control | 0.8 kV |
| | Ambient humidity | Max. 95% RH, non-condensing |
| | Ambient temperature | -22...122°F [-30...50°C] |
| | Storage temperature | -40...176°F [-40...80°C] |
| | Servicing | maintenance-free |
| Weight | Weight | 5.2 lb [2.4 kg] |
| Materials | Housing material | UL94-5VA |

Safety notes

- The device must not be used outside the specified field of application, especially not in aircraft or in any other airborne means of transport.
- Outdoor application: only possible in case that no (sea) water, snow, ice, insolation or aggressive gases interfere directly with the actuator and that is ensured that the ambient conditions remain at any time within the thresholds according to the data sheet.
- Only authorized specialists may carry out installation. All applicable legal or institutional installation regulations must be complied with during installation.
- The device may only be opened at the manufacturer's site. It does not contain any parts that can be replaced or repaired by the user.
- Cables must not be removed from the device.
- To calculate the torque required, the specifications supplied by the damper manufacturers concerning the cross-section and design, as well as the installation site and ventilation conditions, must be observed.
- The device contains electrical and electronic components and must not be disposed of as household refuse. All locally valid regulations and requirements must be observed.

Product features

Operating mode The actuator is controlled via the Cloud, BACnet/IP or Modbus TCP and drives to the position defined by the control signal. Various data points can be written and read via the same interfaces.

Hybrid mode:

The actuator receives its analog control signal from the higher-level controller and moves to the defined position. Using the Cloud, BACnet/IP or Modbus TCP, various data points can be read and, with the exception of the control signal, written.

Product features

Converter for sensors Connection option for two sensors (passive sensor, active sensor or switching contact). The actuator serves as an analog/digital converter for the transmission of the sensor signal to the higher level system.

Communication The configuration can be carried out through the integrated web server (RJ45 connection to the web browser), by communicative means or via the Cloud.
Additional information regarding the integrated web server can be found in the separate documentation.

"Peer to Peer" connection
<http://belimo.local:8080>
 The Notebook must be set to "DHCP".
 Make sure that only one network connection is active.
Standard IP address:
<http://192.168.0.10:8080>
 Static IP address
Password (read-only):
 User name: «guest»
 Password: «guest»

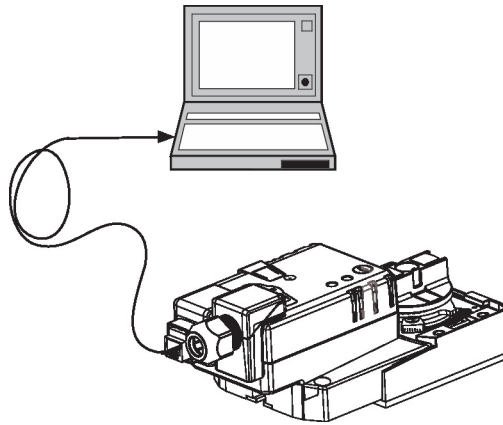

Control signal inversion This can be inverted in cases of control with an analogue control signal. The inversion causes the reversal of the standard behavior, i.e. for control signal 0%, the actuator is opened to max and for control signal 100%, the actuator is closed.

Simple direct mounting Simple direct mounting on the damper shaft with a universal shaft clamp, supplied with an anti-rotation mechanism to prevent the actuator from rotating.

Data recording The recorded data (integrated data recording for 13 months) can be used for analytical purposes.
Download csv files via web browser.

Manual override Manual override with push-button possible (the gear train is disengaged for as long as the button is pressed or remains locked).

Adjustable angle of rotation Adjustable angle of rotation with mechanical end stops.

High functional reliability The actuator is overload protected, requires no limit switches and automatically stops when the end stop is reached.

Home position The first time the supply voltage is switched on, i.e. at the time of commissioning, the actuator carries out an adaptation, which is when the operating range and position feedback adjust themselves to the mechanical setting range.
The actuator then moves into the position defined by the control signal.

Adaptation and synchronization An adaptation can be triggered manually by pressing the "Adaptation" button. Both mechanical end stops are detected during the adaptation (entire setting range).
The actuator then moves into the position defined by the control signal.

Accessories

| Tools | Description | Type |
|-------|---------------------------------------------------------------------------------------------------------------------------------------|---------|
| | Signal simulator, Power supply AC 120 V | PS-100 |
| | Connecting cable 16 ft [5 m], A: RJ11 6/4 LINK.10, B: 6-pin for connection to service socket | ZK1-GEN |
| | Connecting cable 10 ft [3 m], A: RJ11 6/4 LINK.10, B: 3-pin Weidmüller and supply connection | ZK4-GEN |
| | Service tool, with ZIP-USB function, for configurable and communicative Belimo actuators, VAV controller and HVAC performance devices | ZTH US |

Accessories

| Electrical accessories | Description | Type |
|------------------------|---------------------------------------------------------------------------------------------------------------------------------------------------------------------|--------------|
| | Positioner for front-panel mounting | SGF24 |
| | Positioner for wall mounting | SGA24 |
| | Resistor, 500 Ω, 1/4" wire resistor with 6" pigtail wires | ZG-R01 |
| | Cable Gland (NEMA 4 models) | 43442-00001 |
| | Cable conduit connector 1/2" | TF-CC US |
| | Transformer, AC 120 V to AC 24 V, 40 VA | ZG-X40 |
| | Feedback potentiometer 15 kΩ grey | P15000A-F GR |
| | Feedback potentiometer 10 kΩ add-on, grey | P10000A GR |
| | Feedback potentiometer 5 kΩ add-on, grey | P5000A GR |
| | Feedback potentiometer 2.8 kΩ add-on, grey | P2800A GR |
| | Feedback potentiometer 1 kΩ add-on, grey | P1000A GR |
| | Feedback potentiometer 500 Ω add-on, grey | P500A GR |
| | Feedback potentiometer 140 Ω add-on, grey | P140A GR |
| | Auxiliary switch, mercury-free | P475-1 |
| | Auxiliary switch, mercury-free | P475 |
| | Auxiliary switch 2x SPDT add-on | S2A |
| | Auxiliary switch 1x SPDT add-on | S1A |
| | | ZS-T |
| Mechanical accessories | Description | Type |
| | Damper crank arm Slot width 6.2 mm, clamping range ø10...18 mm | KH6 |
| | Damper crank arm Slot width 8.2 mm, clamping range ø10...18 mm | KH8 |
| | Damper crank arm Slot width 8.2 mm, clamping range ø14...25 mm | KH10 |
| | Damper crank arm Slot width 8.2 mm, for ø1.05" | KH12 |
| | Ball joint suitable for damper crank arm KH8 | KG6 |
| | Ball joint suitable for damper crank arm KH8 | KG8 |
| | Ball joint suitable for damper crank arm KH8 / KH10 | KG10A |
| | | SH8 |
| | Push rod for KG10A ball joint L 36", 3/8" diameter | SH10 |
| | | ZG-DC1 |
| | | ZG-DC2 |
| | Weather shield 13x8x6" [330x203x152 mm] (LxWxH) | ZS-100 |
| | Baseplate, for ZS-100 | ZS-101 |
| | Weather shield 406x213x102 mm [16x8-3/8x4"] (LxWxH) | ZS-150 |
| | Shaft extension 240 mm ø20 mm for damper shaft ø8...22.7 mm | AV8-25 |
| | | TF-P |
| | Mounting bracket for AF.. | ZG-100 |
| | Mounting bracket for AF / NF | ZG-101 |
| | Wrench 0.32 in and 0.39 in [8 mm and 10 mm] | TOOL-06 |
| | Adapter for auxiliary switch and feedback potentiometer, Multipack 20 pcs. | Z-SPA |
| | Actuator arm for standard shaft clamp (one-sided) | AH-25 |
| | | K-AM25 |
| | Shaft clamp reversible, clamping range ø10...20 mm | K-SA |
| | Mounting bracket | ZG-109 |
| | Linkage kit | ZG-110 |
| | Mounting bracket for LF.. | ZG-112 |
| | | ZG-JSA-1 |
| | | ZG-JSA-2 |
| | | ZG-JSA-3 |
| | Mounting kit for linkage operation for flat installation | ZG-NMA |
| | Linkage kit | ZG-JSL |
| | Jackshaft RetroFIT+ Linkage with Belimo Rotary Actuators | |
| | Explosion proof housing 16x10x6.435" [406x254x164 mm] (LxWxH), UL and CSA, Class I, Zone 1&2, Groups B, C, D, (NEMA 7), Class III, Hazardous (classified) Locations | ZS-260 |
| | Weather shield 17-1/4x8-3/4x5-1/2" [438x222x140 mm] (LxWxH), NEMA 4X, with mounting brackets | ZS-300 |

Accessories

| Description | Type |
|----------------------------------------------------------------------------------------------|-----------------|
| Weather shield 17-1/4x8-3/4x5-1/2" [438x222x140 mm] (LxWxH), NEMA 4X, with mounting brackets | ZS-300-5 |
| Shaft extension 1/2" | ZS-300-C1 |
| Shaft extension 3/4" | ZS-300-C2 |
| Shaft extension 1" | ZS-300-C3 |
| Baseplate extension for SM..A to SM../AM../SMD24R | Z-SMA ZG-SGF |

Electrical installation



Supply from isolating transformer.

Parallel connection of other actuators possible. Observe the performance data.

Wire colors:

- 1 = black
- 2 = red
- 3 = white
- 5 = orange

MP-Bus

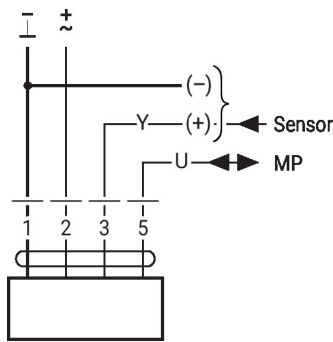

AC/DC 24 V, modulating

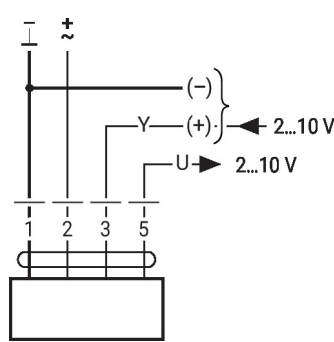

| | | | | |
|---|---|------|--|--|
| 1 | 2 | 3 | | |
| | | 2 V | | |
| | | 10 V | | |

Further electrical installations



The connection diagrams shows connections for the first sensor on terminal S1, while the second sensor can be connected identically on terminal S2.

Parallel use of different sensor types is permitted.

For hybrid operation, S1 is used for the control signal Y and must be configured as an active sensor.

Further electrical installations

Functions with basic values (conventional mode)

Override control with AC 24 V with relay contacts

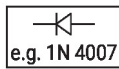
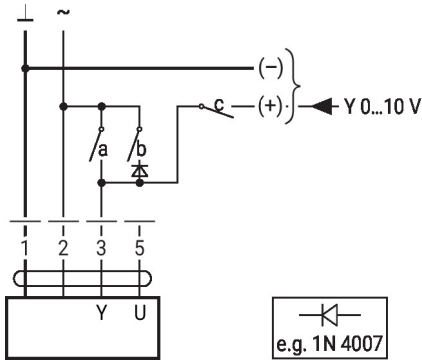

| 1 | 2 | a | b | c | |
|---|---|---|---|---|--------|
| | | | | | 0 % |
| | | | | | ZS 50% |
| | | | | | 100% |
| | | | | | Y |

Override control with AC 24 V with rotary switch

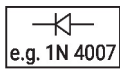
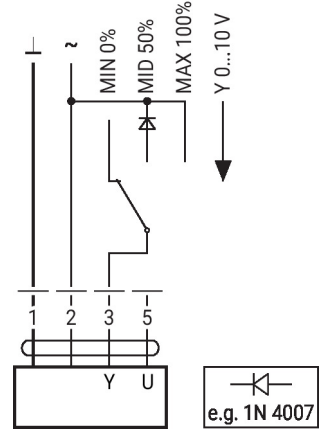

Control remotely 0...100% with positioner SG..

Minimum limit with positioner SG..

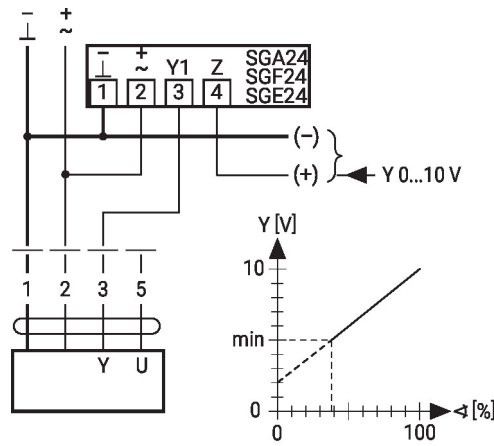
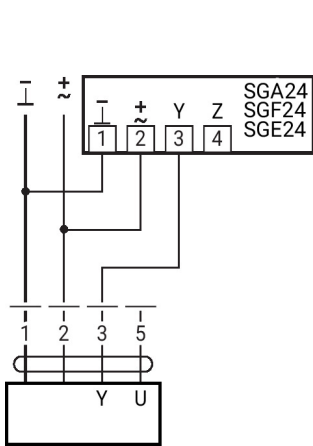

Primary/secondary operation (position-dependent)

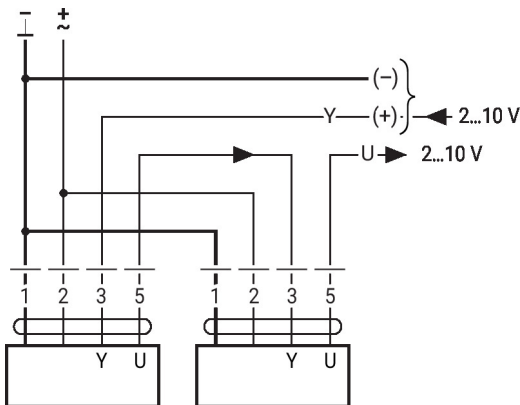

Further electrical installations

Functions with basic values (conventional mode)

Control with 4...20 mA via external resistor

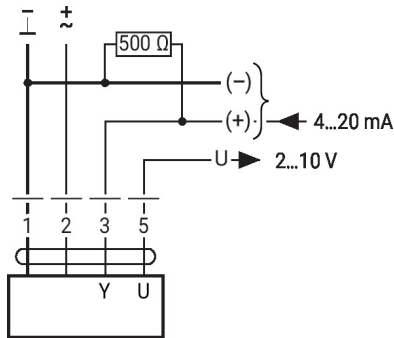

Caution:
 The operating range must be set to DC 2...10 V.
 The 500 Ohm resistor converts the 4...20 mA current signal to a voltage signal DC 2...10 V.

Functional check

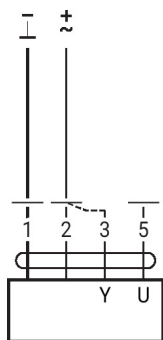

Procedure

1. Connect 24 V to connections 1 and 2
2. Disconnect connection 3:
 - With direction of rotation 0: Actuator rotates to the left
 - With direction of rotation 1: Actuator rotates to the right
3. Short-circuit connections 2 and 3:
 - Actuator runs in opposite direction

Functions with basic values (conventional mode)

MP-Bus Network topology

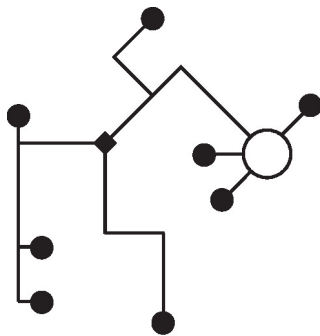

There are no restrictions for the network topology (star, ring, tree or mixed forms are permitted).
 Supply and communication in one and the same 3-wire cable

- no shielding or twisting necessary
- no terminating resistors required

MP-Bus Network topology

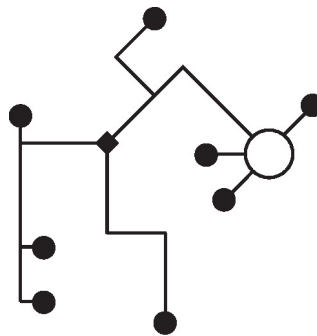

There are no restrictions for the network topology (star, ring, tree or mixed forms are permitted).
 Supply and communication in one and the same 3-wire cable

- no shielding or twisting necessary
- no terminating resistors required

Further electrical installations

Functions with basic values (conventional mode)

Connection on the MP-Bus

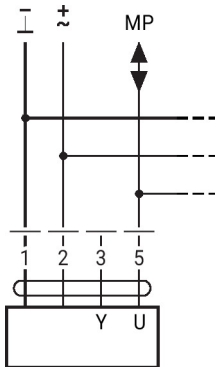

Max. 8 MP-Bus nodes

Connection of active sensors

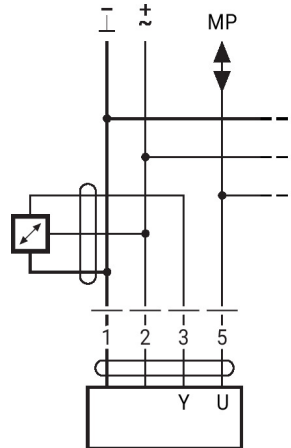

- Supply AC/DC 24 V
- Output signal 0...10 V (max. 0...32 V)
- Resolution 30 mV

Connection of external switching contact

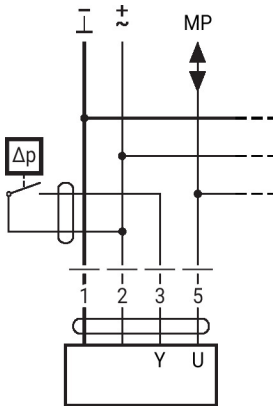

- Switching current 16 mA @ 24 V
- Start point of the operating range must be configured on the MP actuator as ≥ 0.5 V

Connection of passive sensors

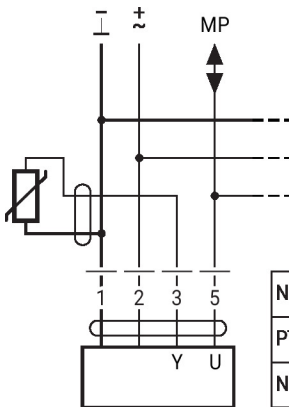

| | | |
|--------|----------------------------|-----------------------------|
| Ni1000 | -28...+98°C | 850...1600 Ω ²⁾ |
| PT1000 | -35...+155°C | 850...1600 Ω ²⁾ |
| NTC | -10...+160°C ¹⁾ | 200 Ω...60 kΩ ²⁾ |

- 1) Depending on the type
 2) Resolution 1 Ohm
 Compensation of the measured value is recommended

Further electrical installations

Functions with specific parameters (configuration necessary)

Override control and limiting with AC 24 V with relay contacts

Control on/off

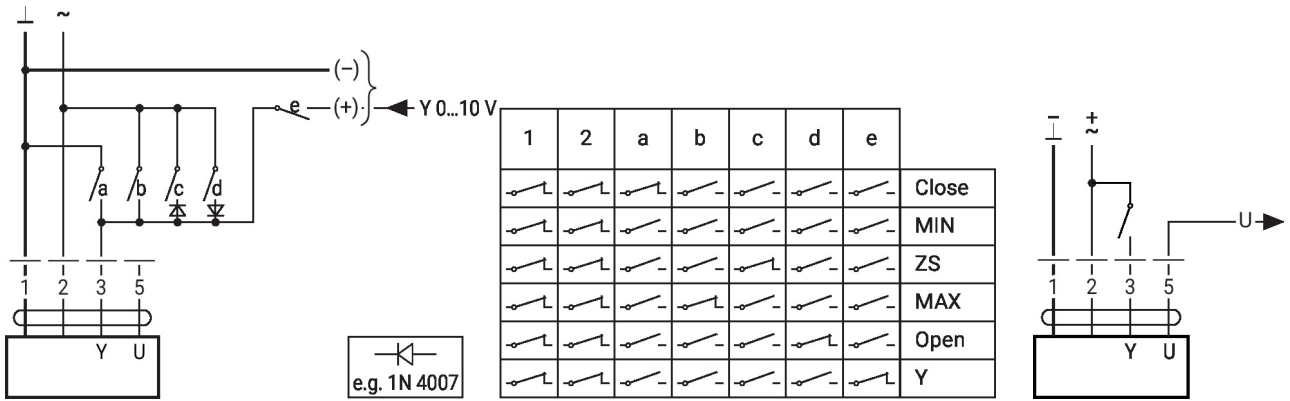

Override control and limiting with AC 24 V with rotary switch

Control 3-point with AC 24 V

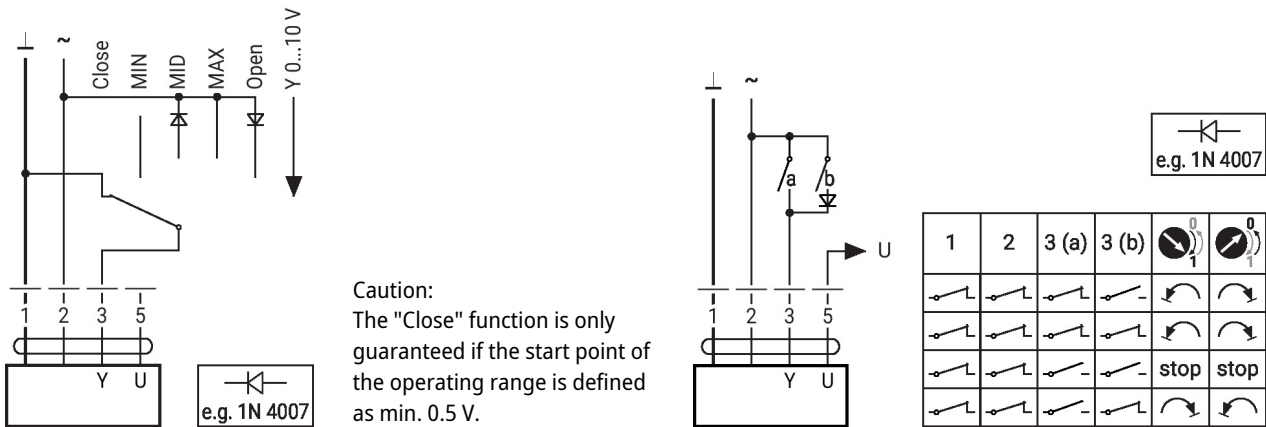

Dimensions

