

## ECON-ZIP-TF1

## Mounting Installation Instructions

**ECON-ZIP-TF1 kit includes:**

- One (1) "L" shaped mounting bracket
- Hardware:
  - Three (3) pan head self-drilling screws 4, 2x13
  - Two (2) M5x70 screws
  - Two (2) hexagon flange nuts M5
- Four (4) tubes for rigid mounting of TF
- One (1) ECON-ZIP-ACT kit
  - Kit includes:
    - One (1) shaft adapter
    - One (1) instruction sheet
  - Hardware:
    - Four (4) nut #6-32 Zinc finish NM grade 2 nylon
    - Four (4) screws #6-32 UNCx1/2" Philips pan head
- One (1) instruction sheet

**1** Verify that you have all the parts listed before installing the linkage.

**2** Remove the Honeywell Black Box Motor (M7XXX) or comparable actuator, without adjusting the current damper linkage assembly.

**3** The Mounting Bracket is provided with the hole patterns to mount the TF series actuator in either a horizontal or vertical position to meet space requirements. Mount the bracket to the holes utilizing the three pan head self-drilling screws 4, 2x13.

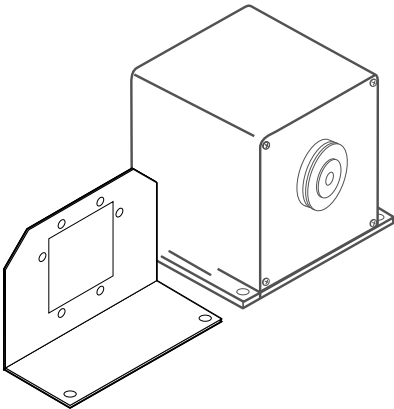

**4** Match the hole pattern of the shaft face to the existing linkage and utilize the #6-32 screws and nuts with the ECON-ZIP-ACT to secure into place. **Note: At least 2 screws and nuts should be used.**

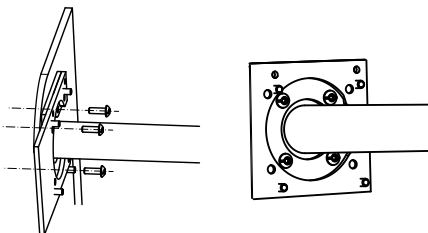

**5** Slide the rigid tubes through the sides of the TF Actuator, 2 per side.

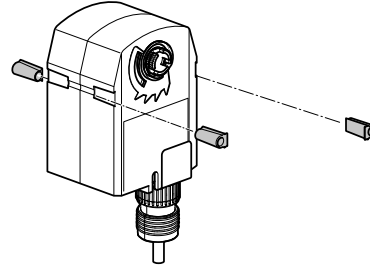

**6** Slide the actuator onto the shaft, Secure the actuator to the mounting plate with the Two Hexagon flange nut M5.

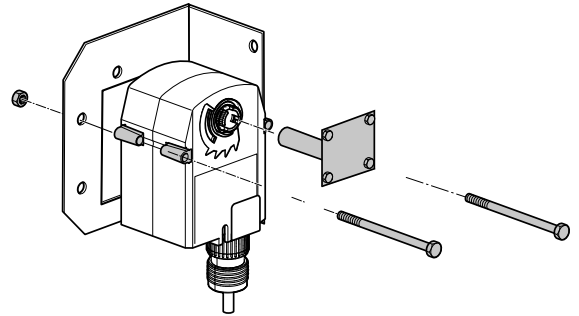

**7** Secure the shaft by tighten the nuts on the V-bolt with a 10mm wrench to 6-8 ft-lb of torque.

