

Operating instructions

22PDP differential pressure sensor

Edition 2022-12/A

Table of contents

	<u>Page</u>
Introduction	
General	4
Warning instructions	4
Prior to installation	4
Mounting	
Mounting the housing	5
Installation	
Stainless steel pressure transmitters	6
Pressure transmitters	6
Pressure transmitter cables	7
Configuration	8
Warning notice	8
Wiring	
Port wiring	9
Starting mode	
Software Version Number	11
Model Pressure Range	11
Output Type	11
User menu	
Menu	12
Down/Up	12
Output (output signal voltage range)	12
Pressure Range	13
Pressure Scale	13
Damping (average value and signal damping)	13
Output (output signal direct/reverse)	14
Pressure Port	14
Backlight	14
Commissioning	
Standard mode	15
Zero calibration	15

Introduction

General

The differential pressure sensor is equipped with two remote pressure transmitters. It can detect pressures in ranges from 0...100 to 0...250 PSI. The overpressure is 2 times and the burst pressure is 20 times the maximum pressure range of the respective model.

The functions of the flexible-use sensor include field-selectable pressure ranges and output signal types, output reversal, selectable averaging or signal smoothing times, as well as port swapping and bi-directional measurements. The output signal is factory calibrated for highest accuracy.

Warning notice



Ensure that the maximum connection or system pressure does not exceed the value specified as the highest pressure for the respective sensor. This corresponds, for example, to a maximum of 100 PSI for the 22PDP-585 sensor model. Measurement inaccuracies could occur if the sensor is operated in the overpressure range. Pressures in excess of the specified value could damage the sensor. See nominal sizes in the table on page 13.

Prior to installation

Read the instructions carefully prior to installation and commissioning of the differential pressure sensor. Noncompliance with these instructions can lead to product damage.

Do not use the sensor in explosive or hazardous environments with combustible or inflammable gases, as a safety or emergency stop device or in other applications in which a product failure could lead to injuries. **Implement protective measures against electrostatic discharges at the time of installation and do not exceed the nominal values of the devices.**

Mounting

Mounting the housing

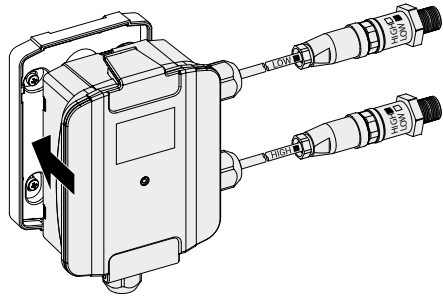

Figure 1

The sensor is mounted on a vertical surface with the mounting plate provided. The grey mounting plate can be detached from the housing and can be used as a drilling template. The four fastening holes of the mounting plate enable fastening with corresponding screws (is included in the scope of delivery).

The housing is inserted back into the mounting plate after the mounting plate has been fastened in place. The cable connections of the remote pressure transmitters are located to the right, and the electrical connection is on the underside of the housing. See Figure 1. Make sure that there is sufficient space present around the device for the electrical connections and that the distance to the pressure measurement sites does not exceed the cable lengths of the pressure transmitters. Avoid mounting positions with strong vibrations or excessive humidity.

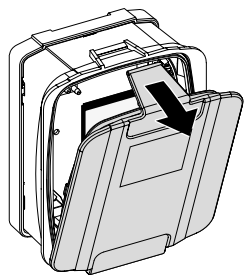

Figure 2

The housing is equipped with a cover with a lid for tool-free opening (snap-fit). Open the covering by pulling on the tab at the top of the housing and remove the covering. Store the removed covering in a suitable location during mounting. See Figure 2.

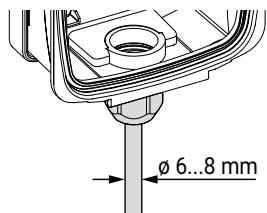

Figure 3

A default cable gland is located on the underside of the housing with a union nut for a cable with a diameter of 6...8 mm. See Figure 3.

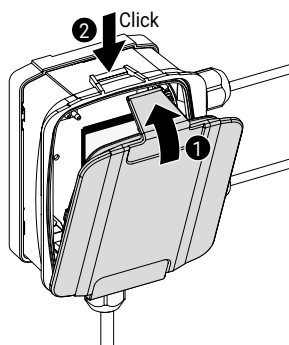

Figure 4

Close the housing after completing the mounting by hooking the covering at the bottom of the curvature and press it against the housing until it clicks into place. See Figure 4.

Installation

Stainless steel pressure transmitters

The two remote stainless steel pressure transmitters and the corresponding connecting cable ends are marked **HIGH** (connection for high pressure) and **LOW** (connection for low pressure). The output signal shows a positive value when the pressure applied at the **HIGH** connection is greater than that at the **LOW** connection. Make sure that the pressure transmitters, as shown in a typical application in Figure 5, are connected correctly. Both pressure transmitters have a $G\frac{1}{4}$ " external thread for connection to the pipe to be monitored. Do not permit any material to fall into the pressure connections, as contaminations could damage the pressure transmitters.

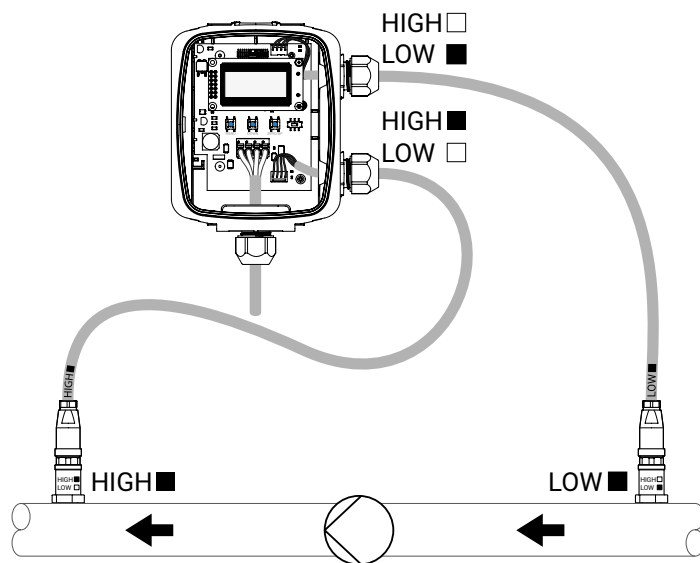

Figure 5

Pressure transmitters

Remove the pressure transmitter marked **HIGH** from the connecting cable by unscrewing the screw cap and then pulling the cable plug from the pressure transmitter.

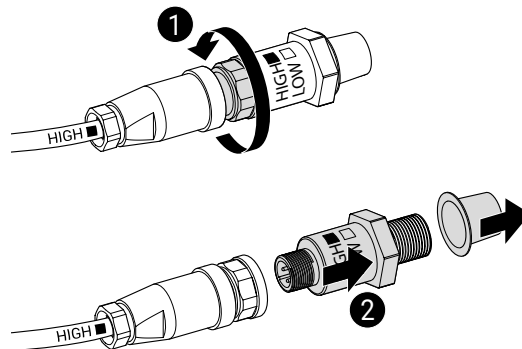

Figure 6

Pressure transmitter cables

Prepare the G $\frac{1}{4}$ " pressure transmitter external thread with a suitable sealing material, e.g. Teflon tape, and screw the pressure transmitter hand-tight into the pipe to be monitored. Use a screw wrench of suitable size to tighten the pressure transmitter securely. See Figure 7.

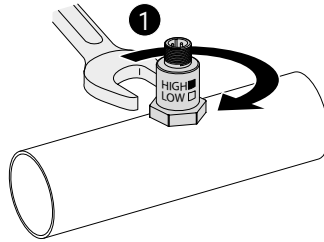

Figure 7

Re-connect the pressure transmitter cable by aligning the cable plug with the pressure transmitter contact (notch-groove), carefully pressing it into the pressure transmitter and then tightening the screw cap hand-tight. Make sure that you are using the pressure transmitter and the cable which are both marked **HIGH**. See Figure 8.

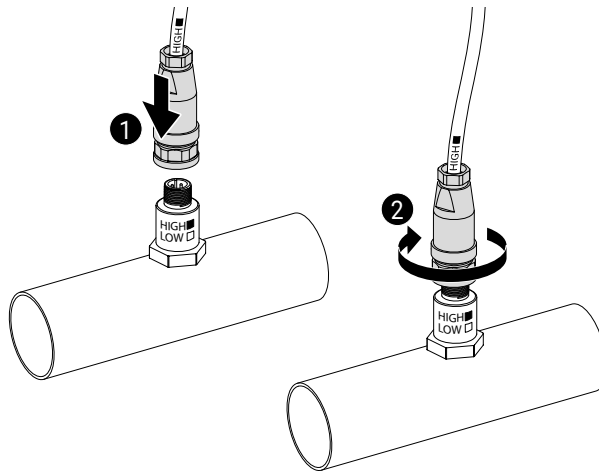

Figure 8

Repeat this for the pressure transmitter marked **LOW**.

Warning notice



Mixing up the pressure transmitters and/or cables marked with **HIGH** and **LOW** has an effect on sensor accuracy.

Configuration

Configuration is carried out to a large extent via the user menu settings in the LCD display and via the push buttons on the circuit board. For further information, consult the User menu section.

Warning notice



The differential pressure sensor must not be connected to the power supply during installation or when changing the output signal type, e.g. from the voltage output to the current output.

Selection of the output signal:

The differential pressure sensor is equipped with output signals for user selection of 4...20 mA, 0...5 V and 0...10 V. The factory setting for operation is voltage output (0...10 V). The sensor can be changed to the current output mode by sliding the output selection switch located on the printed circuit board from the position marked VOLT to the one marked mA. See Figure 9.

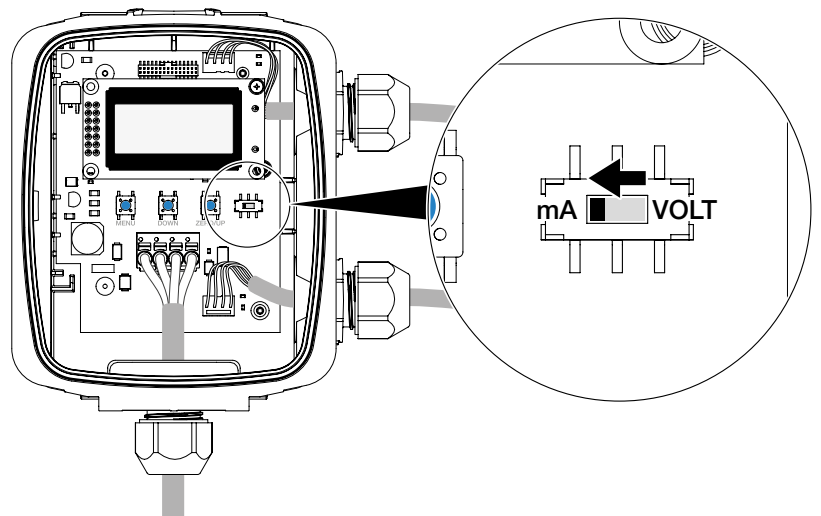

Figure 9

In voltage output mode, you can call up the corresponding user menu to select between a 0...5 V and a 0...10 V output signal range.

Wiring

Port wiring

To avoid electric shock or device damage, deactivate the 24 V AC/DC power supply until all of the connections to the device have been properly made.

Use shielded cables with corresponding core cross-sections for all connections and do not route the device cables in the same conduit as the cables for supplying inductive loads, e.g. motors. Establish all of the connections in accordance with national and local regulations.

Undo the union nut of the cable gland at the underside of the housing to guide the cable through the cable gland and into the housing.

Pull a sufficient length of cable into the housing so that the cable conductors will be easy to handle and no tensile force needs to be applied to the terminal. Complete the wire connections in accordance with the wiring diagram for the applicable power supply and the output signal type.

To simplify installation, you can remove the terminal from the printed circuit board by pulling it upward and off the pins on the circuit board.

Ensure correct placement of the terminal after the wiring is completed. The labelling of the terminal pins on the printed circuit board must be visible in its entirety and must not be hidden by the terminal.

Connect the DC plus or AC voltage hot side to the +/~ terminal (second pin from the left). For the voltage output or the power supply, the DC ground or AC supply common is connected to the ⊥/- terminal (first pin from the left). Do not connect any power to the AO and ZERO connections, because doing so would damage the device. See Figure 10.

The analogue output is available at the AO connection (third pin from the left). Check the analogue input of the controller to determine the correct connection before applying voltage.

When using zero-point calibration with the remote Zero switch, connect it between ZERO (fourth pin from the left) and ground ⊥/- (first pin from the left). Screw the union nut of the cable gland on hand-tight after completing the wiring.

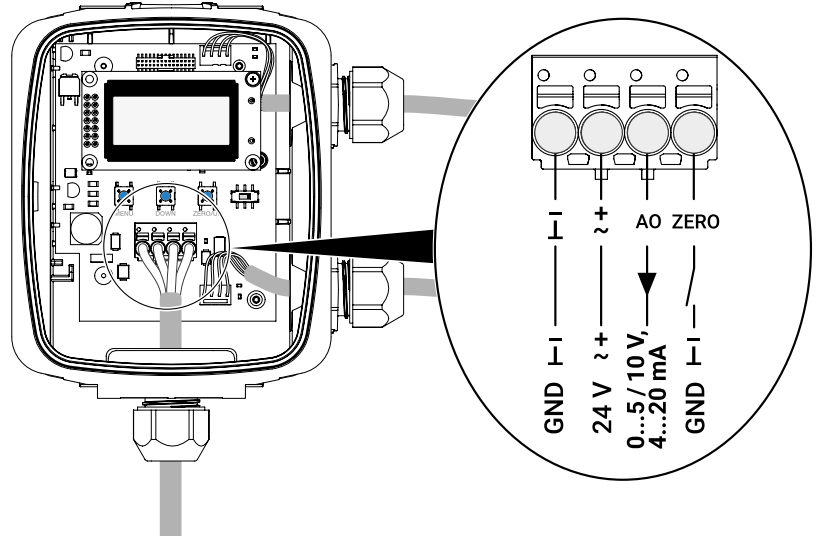

Figure 10

In the event of a separate power supply, ensure that the grounding (DC) or supply common (AC) are connected from the sensor, the controller and the power supply.

Starting mode

The device switches into starting mode when it is supplied with current. The LCD displays the current operating settings for 2 seconds. All of the information in the menu and in the display are in English.

1. Software Version Number

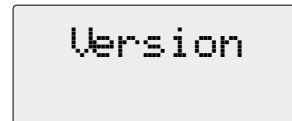
A rectangular LCD display showing the word "Version" in a monospaced font.

2. Model Pressure Range

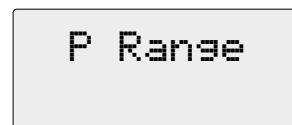
A rectangular LCD display showing the text "P Range" in a monospaced font.

3. Output Type

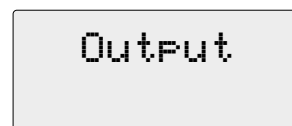
A rectangular LCD display showing the word "Output" in a monospaced font.

At the end of starting mode, the device switches into normal mode and displays the measured differential pressure.

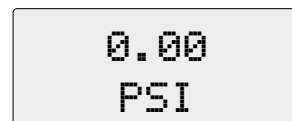
A rectangular LCD display showing the numerical value "0.00" on the top line and the unit "PSI" on the bottom line, both in a monospaced font.

User menu

The user menu can be entered at any time after starting mode by pressing the **<MENU>** button. Please note that the **<ZERO>** button function changes to an **<UP>** button function when a menu is active.

When this is the case, the differential pressure sensor interrupts operation and retains the last pressure value as the output value.

If the user menu has been inactive for 5 minutes (no button pressed), then the menu is exited and the device returns to standard mode.

The operation and parameters of the user menu are explained in the following.

Menu

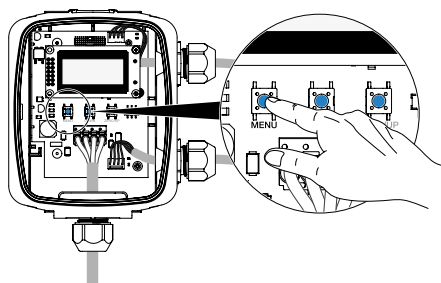

Press the **<MENU>** button and release it again to call up the user menu.

Down/Up

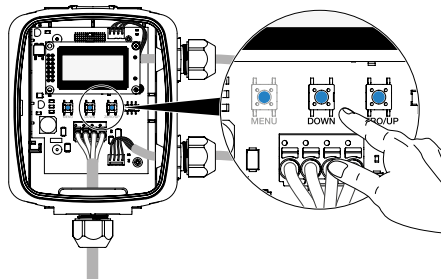

This element appears only when the output signal switch on the circuit board is in VOLT position. Use **<DOWN>** or **<UP>** to set the output signal type to 0...5 or 0...10 V. The factory setting is 0...10 V.

1. Output (output signal voltage range)

```
Output
0-10 Vdc
```

Press the **<MENU>** button to save changes and proceed to the next menu point.

2. Pressure Range

P Range
10 PSI

The pressure range is set by default to the largest range (1) of the model. Use **<DOWN>** or **<UP>** to scroll through the four available model-specific ranges. Available options are displayed as follows:

Product type from Belimo	Pressure range in PSI			
	4	3	2	1
22PDP-585	10.0	20.0	50.0	100.0
22PDP-588	25.0	50.0	125.0	250.0

Press the **<MENU>** button to save changes and proceed to the next menu point.

3. Pressure Scale

P Scale
0 - Max

The default pressure scale is uni-directional from 0 to the maximum range (e.g. 0...100 PSI). Use **<DOWN>** or **<UP>** to switch the setting to a bidirectional scale or measurement (e.g. ± 100 PSI). The setting switches from "0 - Max" to "+/- Max".

Press the **<MENU>** button to save changes and proceed to the next menu point.

4. Damping (average value and signal damping)

Damping
4 Sec

The default time for average value formation for signal damping is 4 seconds. This can be changed with **<DOWN>** or **<UP>** to 1...60 seconds.

Press the **<MENU>** button to save changes and proceed to the next menu point.

5. Output (output signal direct/reverse)

Output
Direct

The analogue output is set by default to direct (4...20 mA, 0...5 V or 0...10 V). **<DOWN>** or **<UP>** can be used to change this to reverse (20...4 mA, 5...0 V or 10...0 V).

Press the **<MENU>** button to save changes and proceed to the next menu point.

6. Pressure Port

P Port
Direct

The pressure port is set by default to Direct (HIGH connection = higher pressure, LOW connection = lower pressure). Use **<DOWN>** or **<UP>** to switch to Reverse (HIGH connection = lower pressure, LOW connection = higher pressure) when the connections need to be swapped in the software due to an installation error.

Press the **<MENU>** button to save changes and proceed to the next menu point.

7. Backlight

Backlite
Auto

The backlight is set by default to Auto operation. **<DOWN>** or **<UP>** can be used to set it to Off, On, or Auto. Auto means that the LCD backlight lights up only when a menu is being accessed, OFF means that it never lights up, and ON means that it is always switched on.

Press the **<MENU>** button to save changes and proceed to the next menu point.

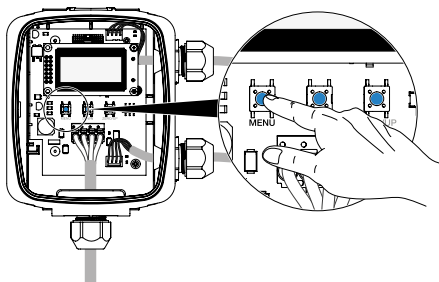

Commissioning

Standard mode

In standard mode, the device reads out the pressure transmitter and calculates the differential pressure depending on the selected range. The differential pressure is displayed on the LCD and is provided as current or voltage at the analogue output. The output value is updated once per second.

To measure and display the differential pressure correctly, the pressure present at the HIGH connection must be higher than that at the LOW connection. When the pressure connections are switched, the sensor always outputs 0 V or 4 mA. When this is the case, it is possible to switch the pressure connections in the menu. It should be noted that, for correct measurement, the connecting cable marked HIGH must always be connected with the HIGH pressure transmitter, and the cable marked LOW must always be connected with the LOW pressure transmitter.

If the LOW connection remains open to ambient pressure, then the HIGH connection is used to measure a positive pressure.

To achieve a positive output behaviour, the pressure applied at the HIGH connection for bidirectional operation should be higher than that at the LOW connection. Negative pressure is displayed when the pressure at the HIGH connection is lower than that at the LOW connection.

The differential pressure sensor shows a linear behaviour with respect to the differential pressure measured and the corresponding signal output value. This means for example that, for a 0...100 PSI sensor in uni-directional operation, 0 PSI = 0 V or 4 mA and 100 PSI = 5 or 10 V or 20 mA, while in bi-directional operation -100 PSI = 0 V or 4 mA and +100 PSI = 5 or 10 V or 20 mA. 0 PSI corresponds in this case to 2.5 or 5 V or 12 mA.

The output value can be influenced by device settings, such as the time for signal damping or average value formation.

The setting of the average pressure value calculations defines how many measured values are applied for averaging and thus as the basis for the output value. If, for example, the average pressure value calculation is set to 30 seconds, then 30 one-second measured values are saved and averaged to form the output value. The next second adds a new measured value and deletes the first in the series in order to calculate a new 30-second average for the output. The output is updated every second with a new average value. The user menu can be applied to set average value from 1 to 60 seconds.

In standard mode, the device also monitors the **<DOWN>**, **<ZERO/UP>** and **<MENU>** buttons and initiates corresponding measures. The buttons are used to access the user menu. The device also monitors the VOLT/mA switch to determine the suitable output signal scale. The user menu can be used to set the voltage range to either 0...5 V or 0...10 V.

Zero calibration

An zero-point calibration of the sensor can be initiated by pressing the internal **<ZERO>** button and holding it down for a minimum of 3 seconds. Once both pressure connections are near zero, the device calculates with a new zero point. Zero-point calibration can also be initiated by holding the ZERO terminal for at least 3 seconds on ground potential by pressing the remotely mounted Zero switch.

Generally speaking, performing a measurement range calibration in the field is not recommended. This holds true unless a high-quality calibration standard with low differential pressure ranges is available and an unchanging sensor temperature can be ensured during the calibration procedure.

All inclusive.

Belimo as a global market leader develops innovative solutions for the controlling of heating, ventilation and air-conditioning systems. Damper actuators, control valves, sensors and meters represent our core business.

Always focusing on customer value, we deliver more than only products. We offer you the complete product range for the regulation and control of HVAC systems from a single source. At the same time, we rely on tested Swiss quality with a five-year warranty. Our worldwide representatives in over 80 countries guarantee short delivery times and comprehensive support through the entire product life. Belimo does indeed include everything.

The "small" Belimo devices have a big impact on comfort, energy efficiency, safety, installation and maintenance.

In short: Small devices, big impact.



5-year warranty



On site around the globe



Complete product range



Tested quality



Short delivery times



Comprehensive support



BELIMO Automation AG

Brunnenbachstrasse 1, 8340 Hinwil, Switzerland

+41 43 843 61 11, info@belimo.ch, www.belimo.com

BELIMO[®]