



5-year warranty



**Type overview**

Type	Stroke
FGVL	1.25" [32 mm] AVK, 2" [50 mm] EV/RV

**Technical data**

<b>Functional data</b>	Fluid	chilled or hot water and steam
	Fluid Temp Range (water)	Please Refer to Manufacturer's Valve Specifications
	Mounting Position	360°
	Applicable valve size	2.5...6" [65...150]
<b>Materials</b>	Hardware	SS and Nickel plated steel
	Housing material	Die cast aluminium and plastic casing
	Stem	316 stainless steel
	Stem adapter	steel/Aluminum
	Frame, plate, base	aluminum, steel (fits competitor bonnets up to 2.3" dia.)
	Collar	aluminum
	Coupling	GF Nylon supplied
<b>Suitable actuators</b>	Non-Spring	EVB(X) RVB(X)
	Electrical fail-safe	AVKB(X)
	For close-off pressure reference Select Pro or retrofit technical documentation.	

**Product features**

<b>Default/Configuration</b>	The default set up for a FGVL linkage will be factory installed along with an AVK or EV, RV series actuator. Included in the kit will be all the necessary hardware to facilitate mounting to the valve.
------------------------------	--

**Dimensions**

Type	Weight
FGVL	9.0 lb [4.1 kg]

EVB, EVX, RVB, RVX

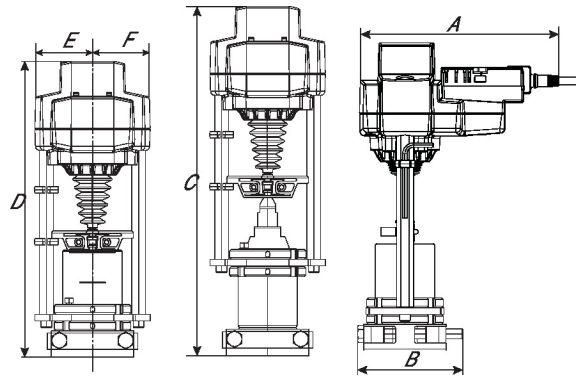

A	B	C	D	E	F
9.2" [234]	5.0" [127]	16.7" [425]	14.0" [355]	2.8" [71]	2.8" [71]

AVKB, AVKX

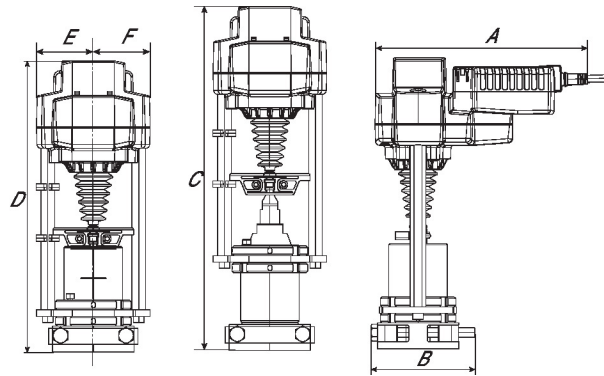

A	B	C	D	E	F
10.2" [260]	5.0" [127]	16.7" [425]	14.0" [355]	2.8" [71]	2.8" [71]



5-year warranty



## Technical data

<b>Electrical data</b>	Nominal voltage	AC/DC 24 V
	Nominal voltage frequency	50/60 Hz
	Power consumption in operation	5 W
	Power consumption in rest position	1.5 W
	Transformer sizing	7.5 VA (class 2 power source)
	Electrical Connection	18 GA plenum cable, 3 ft [1 m], with 1/2" conduit connector, degree of protection NEMA 2 / IP54
	Overload Protection	electronic throughout full stroke
Electrical Protection	actuators are double insulated	
<b>Functional data</b>	Actuating force motor	2500 N [560 lbf]
	Operating range Y	2...10 V
	Operating range Y note	4...20 mA w/ ZG-R01 (500 Ω, 1/4 W resistor)
	Input Impedance	100 kΩ for 2...10 V (0.1 mA), 500 Ω for 4...20 mA
	Position feedback U	2...10 V
	Position feedback U note	Max. 0.5 mA
	Direction of motion motor	selectable with switch 0/1
	Manual override	5 mm hex crank (3/16" Allen), supplied
	Stroke	2" [50 mm]
	Running Time (Motor)	90 s /
	Running time motor variable	90 or 150 s
	Noise level, motor	60 dB(A)
	Position indication	Mechanically, with pointer
<b>Safety data</b>	Degree of protection IEC/EN	IP54
	Degree of protection NEMA/UL	NEMA 2
	Enclosure	UL Enclosure Type 2
	Agency Listing	cULus acc. to UL60730-1A/-2-14, CAN/CSA E60730-1:02, CE acc. to 2014/30/EU and 2014/35/EU; Listed to UL 2043 - suitable for use in air plenums per Section 300.22(c) of the NEC and Section 602.2 of the IMC
	Quality Standard	ISO 9001
	Ambient temperature	-22...122°F [-30...50°C]
	Storage temperature	-40...176°F [-40...80°C]
	Ambient humidity	Max. 95% RH, non-condensing
	Servicing	maintenance-free
	<b>Materials</b>	Housing material

**Footnotes** † Use flexible metal conduit. Push the listed conduit fitting device over the actuator's cable to butt against the enclosure. Screw in conduit connector. Jacket the actuators input wiring with listed flexible conduit. Properly terminate the conduit in a suitable junction box. Rated impulse Voltage 800V. Type of action 1. Control pollution degree 3.

**Electrical installation**

**✂ INSTALLATION NOTES**

- Actuators may also be powered by DC 24 V.
- A 500 Ω resistor (ZG-R01) converts the 4...20 mA control signal to 2...10 V.
- Actuators with plenum cable do not have numbers; use color codes instead.
- Meets cULus requirements without the need of an electrical ground connection.

**Warning! Live electrical components!**

During installation, testing, servicing and troubleshooting of this product, it may be necessary to work with live electrical components. Have a qualified licensed electrician or other individual who has been properly trained in handling live electrical components perform these tasks. Failure to follow all electrical safety precautions when exposed to live electrical components could result in death or serious injury.

**Wiring diagrams**

VDC / 4 to 20 mA

