



5-year warranty



Type overview

Type	Stroke
UGVL	0.6" [15 mm] LV, 3/4" [20 mm] SV

Technical data

Functional data	Fluid	chilled or hot water and steam
	Fluid Temp Range (water)	Please Refer to Manufacturer's Valve Specifications
	Mounting Position	360°
	Applicable valve size	0.5...2" [15...50]
Materials	Hardware	SS and Nickel plated steel
	Stem adapter	aluminum, steel (fits stems up to .66" dia both threaded or slotted.)
	Frame, plate, base	aluminum, steel
	Collar	aluminum, steel, (fits bonnets up to 1.7" dia both threaded or notched.)
	Coupling	GF Nylon supplied
Suitable actuators	Non-Spring	LVB(X) SVB(X)
	Electrical fail-safe	LVKB(X) SVKB(X)
	For close-off pressure reference Select Pro or retrofit technical documentation.	

Product features

Default/Configuration	The default set up for a UGVL linkage will be factory installed along with a LV or SV series actuator. Included in the kit will be all the necessary hardware to facilitate mounting to the valve.
------------------------------	--

Dimensions

Type	Weight
UGVL	4.2 lb [1.9 kg]

LVB, LVX, SVB, SVX

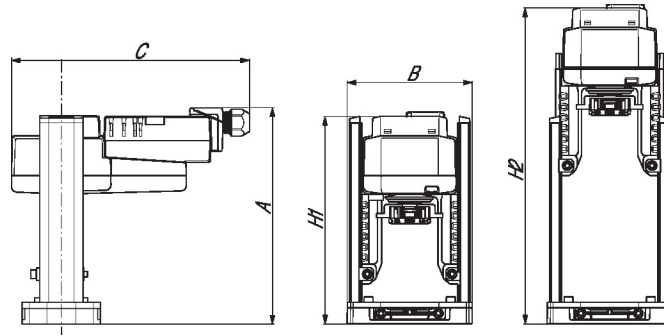

A	B	C	H1	H2
8.0" [203]	4.4" [112]	8.6" [219]	7.5" [190]	11.4" [290]

LVKB, LVKX, SVKB, SVKX

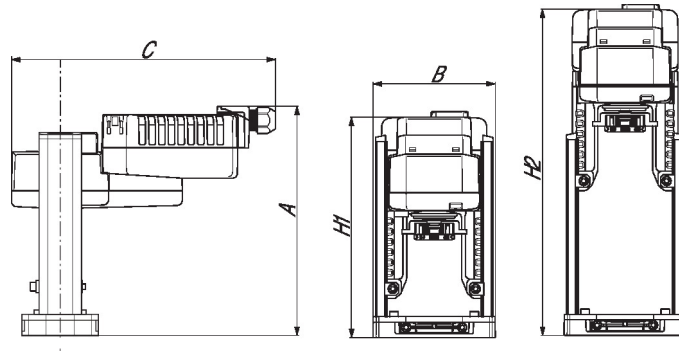

A	B	C	H1	H2
8.5" [216]	4.4" [112]	9.6" [244]	8.4" [207]	12.1" [307]

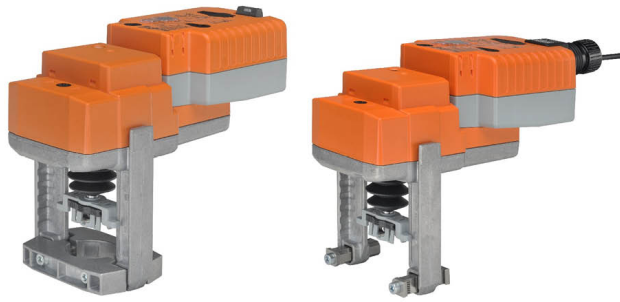

5-year warranty



Technical data

Electrical data	Nominal voltage	AC 100...240 V
	Nominal voltage frequency	50/60 Hz
	Power consumption in operation	3 W
	Power consumption in rest position	2 W
	Transformer sizing	7 VA (class 2 power source)
	Electrical Connection	18 GA appliance cable with 1/2" conduit connector, 3 ft [1 m], degree of protection NEMA 2 / IP54
	Overload Protection	electronic throughout full stroke
	Electrical Protection	actuators are double insulated
	Functional data	Actuating force motor
Position feedback U note		No Feedback
Bridging time (PF)		2 s
Pre-charging time		5...20 s
Direction of motion motor		selectable with switch
Direction of motion fail-safe		reversible with switch
Manual override		4 mm hex crank (shipped w/actuator)
Stroke		0.75" [19 mm]
Running Time (Motor)		90 s /
Running time motor variable		90 or 150 s
Running time fail-safe		<35 s
Noise level, motor		45 dB(A)
Noise level, fail-safe		60 dB(A)
Position indication	Mechanically, with pointer	
Safety data	Degree of protection IEC/EN	IP54
	Degree of protection NEMA/UL	NEMA 2
	Enclosure	UL Enclosure Type 2
	Agency Listing	cULus acc. to UL60730-1A/-2-14, CAN/CSA E60730-1:02, CE acc. to 2014/30/EU and 2014/35/EU
	Quality Standard	ISO 9001
	Ambient temperature	-22...122°F [-30...50°C]
	Storage temperature	-40...176°F [-40...80°C]
	Ambient humidity	Max. 95% RH, non-condensing
	Servicing	maintenance-free
Materials	Housing material	Die cast aluminium and plastic casing

Footnotes † Use flexible metal conduit. Push the listed conduit fitting device over the actuator's cable to butt against the enclosure. Screw in conduit connector. Jacket the actuators input wiring with listed flexible conduit. Properly terminate the conduit in a suitable junction box. Rated impulse Voltage 800V. Type of action 1. Control pollution degree 3.

Electrical installation

✂ INSTALLATION NOTES

(A) Actuators with appliance cables are numbered.

(2) Actuators may be connected in parallel. Power consumption and input impedance must be observed.

◆ Meets cULus requirements without the need of an electrical ground connection.

(1) Warning! Live electrical components!

During installation, testing, servicing and troubleshooting of this product, it may be necessary to work with live electrical components. Have a qualified licensed electrician or other individual who has been properly trained in handling live electrical components perform these tasks. Failure to follow all electrical safety precautions when exposed to live electrical components could result in death or serious injury.

Wiring diagrams

On/Off

100 to 240 VAC

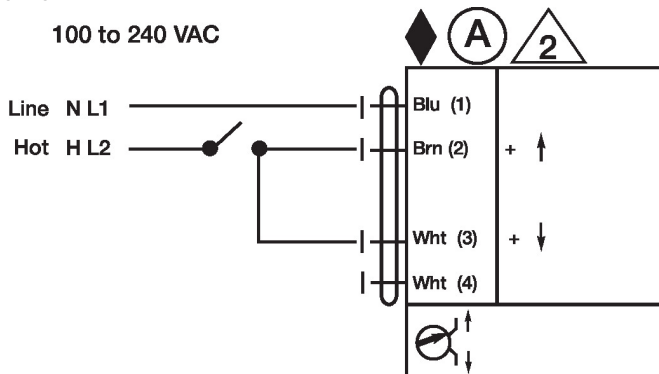

Floating Point

100 to 240 VAC

