

Room sensor CO₂ / Humidity / Temperature

For measuring temperature, humidity and CO₂ in the room and for controlling the room temperature and/or ventilation. The high-contrast ePaper touch display ensures best readability and intuitive operation. Thanks to MP-Bus communication and integrated analog outputs, the room operating units can be seamlessly connected to existing third-party controllers. Commissioning and configuration of the devices are conveniently done with Belimo Assistant 2. The ePaper display can be optimized for a wide range of applications.



5-year warranty

Type Overview

Type	Communication	Output signal active CO ₂	Output signal active humidity	Output signal active temperature
22RTM-5800D	MP-Bus	0...5 V, 0...10 V, 2...10 V, 4...20 mA	0...5 V, 0...10 V, 2...10 V, 4...20 mA	0...5 V, 0...10 V, 2...10 V, 4...20 mA
22RTH-5800D	MP-Bus	-	0...5 V, 0...10 V, 2...10 V, 4...20 mA	0...5 V, 0...10 V, 2...10 V, 4...20 mA

Technical data

Electrical Data	Nominal voltage	AC/DC 24 V
	Nominal voltage range	AC 19.2...28.8 V / DC 19.2...28.8 V
	Power consumption AC	max. 1 VA (V output) max. 4 VA (mA output)
	Power consumption DC	max. 0.5 W (V output) max. 2 W (mA output)
	Electrical connection	Spring-loaded terminal 0.25...1.5 mm ²
	Electrical connection note	Cable type USA and Canada: CL2 or higher
	Cable entry	Back side Top side Bottom side
	Data bus communication	Communication
Number of nodes		MP-Bus max. 8 (16)
Functional Data	Medium	Air
	Display	ePaper touch display and LED, 2.72x2.44" [69x62 mm] The LED is used for the CO ₂ TLF (traffic light function). The LED can be configured and deactivated via Belimo Assistant 2. (Type (P-)22RTM-..).
	Input/Output	3x analog output: 0...10 V (factory setting), 0...5 V, 2...10 V, or 4...20 mA, selectable with Belimo Assistant 2

Technical data

Functional Data	Input/Output Note	V output: Min. resistance 5 kΩ mA output: max. resistance 500 Ω
Measuring Data	Measured values	CO ₂ relative humidity Dew point Temperature
Specification CO₂	Sensing element technology	Non-dispersive infrared (NDIR) dual channel
	Measuring range	default setting: 0...2000 ppm
	Accuracy	±(50 ppm + 2% of measured value)
	Long term stability	±20 ppm p.a.
Specification temperature active	Measuring range	32...122°F [0...50°C] (default setting)
	Accuracy temperature	±0.3°C @ 25°C [±0.5°F @ 77°F]
	Long-term stability	±0.05°F p.a. @ 77°F [±0.03°C p.a. @ 25°C]
Specification Humidity	Measuring range	Default setting: 0...100% RH
	Measuring range dew point	Default setting: -58...122°F [-50...50°C]
	Accuracy	±2% between 0...90% RH @ 77°F [25°C]
	Long term stability	±0.25% RH p.a. @ 77°F [25°C]@ 50% RH
Safety Data	Protection class IEC/EN	III, Safety Extra-Low Voltage (SELV)
	Degree of protection IEC/EN	IP30
	Degree of protection NEMA/UL	NEMA 1
	EU Conformity	CE Marking
	Quality Standard	ISO 9001
	UL Approval	cULus according to UL60730-1, CAN/CSA E60730-1
	Rated impulse voltage supply	0.5 kV
	Pollution degree	2
	Ambient humidity	Max. 95% RH, non-condensing
	Ambient temperature	32...122°F [0...50°C]
Storage temperature	-40...160°F [-40...70°C]	
Materials	Housing	PC, white, RAL 9003

Safety Notes

This device has been designed for use in stationary heating, ventilation and air-conditioning systems and must not be used outside the specified field of application. Unauthorized modifications are prohibited. The product must not be used in relation with any equipment that in case of a failure may threaten humans, animals or assets.

Ensure all power is disconnected before installing. Do not connect to live/operating equipment.

Only authorized specialists may carry out installation. All applicable legal or institutional installation regulations must be complied with during installation.

The device contains electrical and electronic components and must not be disposed of as household refuse. All locally valid regulations and requirements must be observed.

Product Features

California Title 24 The device complies with the requirements outlined in California Title 24 and Cal Green, which mandates carbon dioxide monitoring in classrooms. This ensures that educational environments adhere to state regulations for air quality, promoting a healthier and safer atmosphere for both students and staff.

Dynamic temperature compensation Active temperature sensors with electronic components always have a thermal dissipation that influences the temperature measurement. The dissipative heat correlates with the level of the applied supply voltage and the levels of the analog outputs.
Belimo room temperature sensors have adaptive temperature compensation, which reliably compensates for the device's self-heating for all permissible supply voltages and output levels. This ensures that the room temperature is recorded with maximum accuracy at all times.

CO₂ dual-duct technology All CO₂ sensors are subject to drift, which is caused by the ageing process of the components and requires regular calibration and adjustment or replacement of the sensors. The dual-duct technology minimizes this drift by compensating for the majority of the ageing effects of the measuring duct through adjustment with a reference duct.
This makes it possible to use dual-channel sensors in applications with 24/7 occupancy. Regular calibration with fresh outdoor air, as is the case with sensors with ABC logic, is not necessary with dual-duct sensors. Recalibration of the sensor is recommended after 5 years of operation.

Remarks

General Remarks Concerning Sensors The measuring result is influenced by the thermal characteristics of the wall. A solid concrete wall responds to thermal fluctuations within a room more slowly than a light-weight structure wall. A room sensor always detects a mixture of air and wall temperature. This means that the radiant heat of the wall, which is important for comfort, is also included in the measurement result.

Remark: Occurring draft leads to a better carrying-off of dissipative power at the sensor. Thus temporally limited fluctuations might occur upon temperature measurement.

Application notice for humidity sensors The humidity sensor is extremely sensitive. Touching the sensor element or exposing it to aggressive substances like chlorine, ozone, ammonia, hydrogen peroxide or ethanol (i.e. as a cleaning agent) may affect the measurement accuracy.
Long-term operation outside the recommended conditions (5...50°C and 20...80% RH) can result in a temporary offset. After returning into the recommended range, this effect disappears.

Indicators and Operation

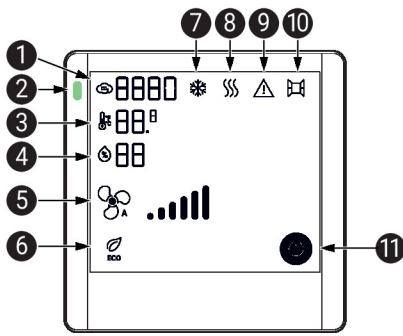

- 1 Current CO₂ concentration: 0...2000 ppm
- 2 CO₂ TLF (traffic light function), available on the (P-)22RTM-.. sensor
Colors: green, yellow and red. LED can be configured and deactivated via Belimo Assistant 2.
- 3 Current temperature: 0...50°C or -32...122°F
- 4 Current relative humidity: 0...99%
- 5 Fan speed display: 6 levels
- 6 Eco mode: Symbol is displayed if this mode is activated
- 7 Cooling mode: Information provided by controller via bus
- 8 Heating mode: Information provided by controller via bus
- 9 Warning / Error
Symbol is displayed if an internal error occurred or if warning is transmitted by the controller via the connected bus (external error).
- 10 External input, information provided by controller via bus
- 11 HVAC system status
Symbol is displayed if the HVAC system is either completely off or in building protection mode. If this symbol is activated, the rest of the display is blank.

Indicators and Operation

Operation The operating elements on the ePaper display are touch fields that can be operated with the finger. The touch fields are only active if the corresponding element is also displayed.

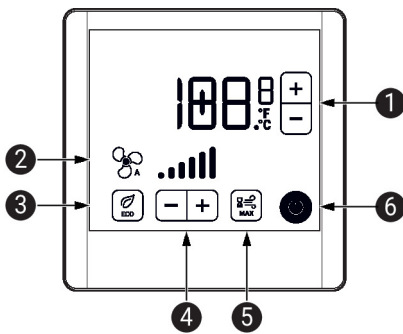

- 1 **Temperature setpoint: Set the desired temperature**
Absolute setpoint: 10...40.0°C or 50...104.0°F
Relative setpoint: -5...5°C / °F
Adjustable and restrictable via Belimo Assistant 2
- 2 Fan speed display: 6 levels
- 3 Eco mode: Symbol is displayed if this mode is activated
- 4 Fan speed setpoint: Set the desired fan level
- 5 Max mode: Symbol is displayed if this mode is activated
- 6 HVAC system status
Symbol can be displayed if the HVAC system is either completely off or in building protection mode. If this symbol is activated, the rest of the display is blank.

Parts included

Screws

Accessories

Tools	Description	Type
	Service tool for wired and wireless setup, on-site operation and troubleshooting.	Belimo Assistant 2
	Belimo Assistant Link Bluetooth and USB to NFC and MP-Bus converter for configurable and communicative devices	LINK.10

Service

- NFC connection** Belimo devices marked with the NFC logo can be operated with the Belimo Assistant 2.
- Requirement:
- NFC- or Bluetooth-capable smartphone
 - Belimo Assistant 2 (Google Play and Apple AppStore)
- Align NFC-capable smartphone on the device so that both NFC antennas are superposed.
- Connect Bluetooth-enabled smartphone via the Bluetooth-to-NFC converter ZIP-BT-NFC to the device. Technical data and operating instructions are shown in the ZIP-BT-NFC data sheet.

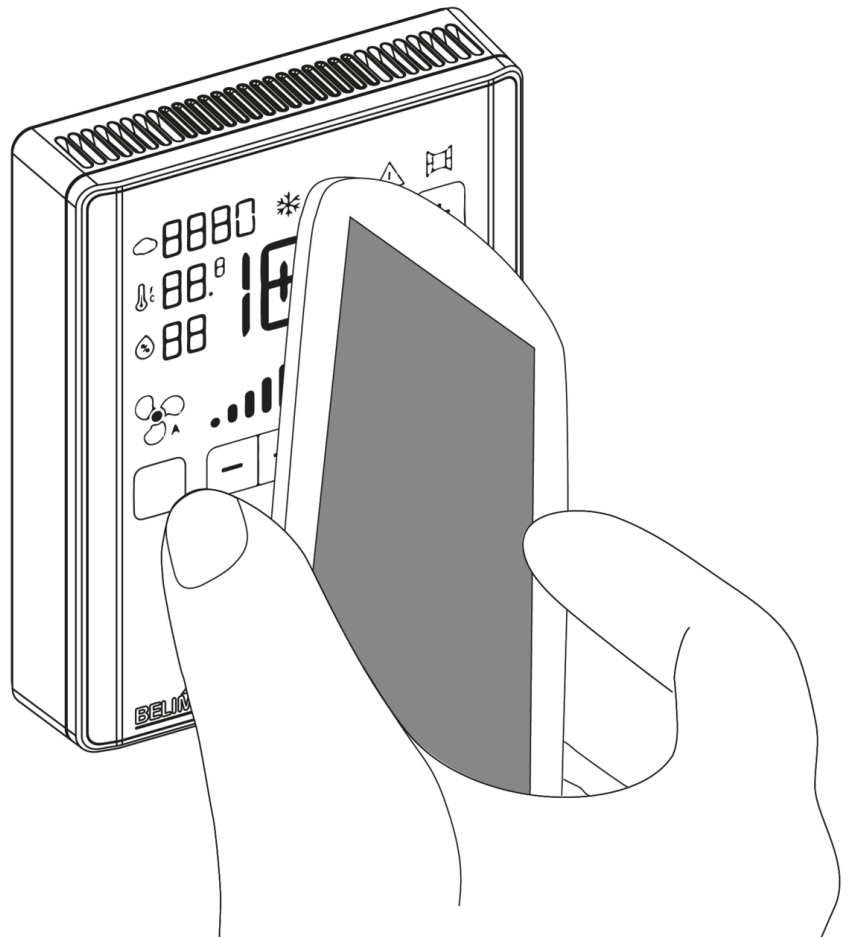

Wiring Diagram



Analog outputs: The analog outputs AO1, AO2 and AO3 can be configured via NFC.

Factory settings:

AO1: Temperature

AO2: Setpoint Temperature

AO3: 22RTH: Humidity, 22RTM: CO₂"

Wiring Diagram

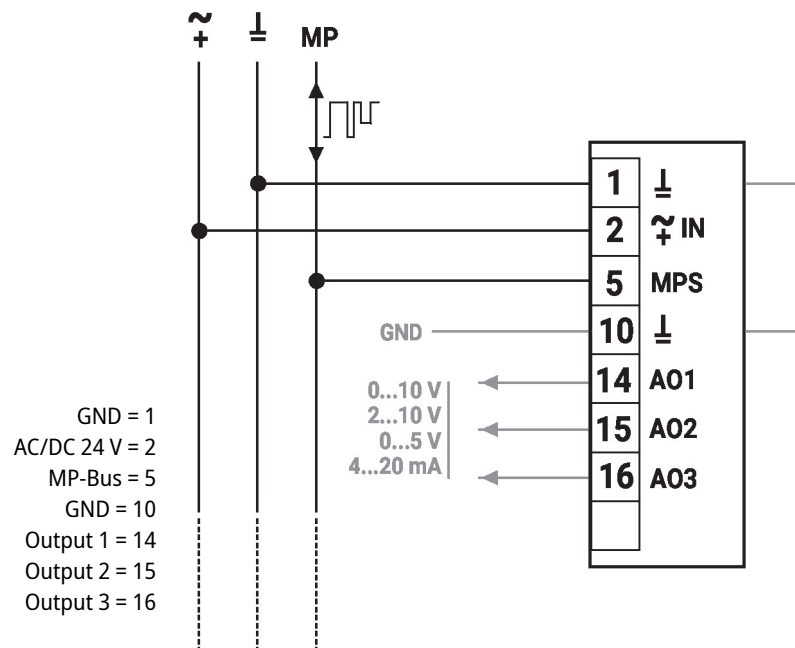

Further documentation

- Overview MP Cooperation Partners
- Description Data-Pool Values
- Installation instructions
- Quick Guide – Belimo Assistant 2