

Gas monitor

Belimo gas monitors are factory calibrated and can monitor up to two gases simultaneously. All monitors feature audible and visual alarms and CAN bus communication, allowing for standalone operation and networking of up to 32 devices. Select models feature relays and analog outputs to control ventilation directly, as well as BACnet MS/TP allowing for integration into a BMS. All gas monitors are wired via a daisy chain and are backed by a five-year warranty.



5-year warranty



Gas Monitor



Type Overview

Type	Measured values	Number of relays	Number of analog outputs	Communication
22G14-5A	NO ₂	1	2	CAN bus, BACnet MS/TP
22G14-5B	NO ₂	2	0	CAN bus, BACnet MS/TP
22G14-5C	NO ₂	0	0	CAN bus

Technical data

Electrical Data	Nominal voltage	AC/DC 24 V
	Nominal voltage note	Please see the remarks section for nominal voltage details and nominal voltage range.
	Nominal voltage frequency	50/60 Hz
	Power consumption AC	5 VA
	Power consumption DC	1.7 W
	Cable entry	2 top, 2 bottom, 1 rear – 1/2" EMT
	Cable specification	Power cable: 18...20 AWG Communication cable: 22...24 AWG twisted pair, shielded jacketed, low capacitance Please see the remarks section for more information about cable size and polarity.
	Fuse	Thermal PTC, auto-reset
Data bus communication	Communication	CAN bus BACnet MS/TP
	Functional Data	
Medium	Air	
Output signal active note	Analog outputs: 2...10 V or 4...20 mA default Configurable for any output (0...5 V, 1...5 V, 0...10 V, etc.) and min/max selectable	

Technical data

Functional Data	Output signal relay note	Relays: SPDT, 5A @ AC 125 V, non-inductive Please see Remarks section for relay rating.	
	Mounting	Please see installation notes section for mounting height recommendations.	
	Max. altitude	6562 ft [2000 m] above sea level	
	Max. altitude note	Calibration verification is recommended above 2000 ft [610 m]	
	Coverage area	Radius: 15 m [50 ft] Area: 700 m ² [7500 ft ²] There can be no obstructions such as walls, elevators, stairs, shelving with solid fill, tool chests, etc. Otherwise the time weighted average (TWA) for the gas to reach the monitor will increase.	
	Display	LCD with backlight showing gas type, gas concentration, alarm level status	
	Alarm	Alarm level 1: Visual alarm (red LED) Alarm level 2: Visual alarm (red LED) Alarm level 3: Visual and audible alarm (flashing white strobe LED and horn) Horn: 80 dB @ 1 m [3.3ft]	
	Warm-up time	5 minutes	
	Measuring Data	Measured values	NO ₂
	Specification gas	Sensing element technology	Electro-chemical
Measuring range		NO ₂ : 0...10 ppm	
Accuracy		NO ₂ : 0...6.5% FS from 0...2 ppm @ 23.5 °C [74°F] FS: Full scale of the measuring range Please see the remarks section for more information about the accuracy of NO ₂ sensors.	
Measurement repeatability		<+2% NO ₂ equivalent	
Long term stability		NO ₂ : <2% per month	
Calibration		Non-interactive zero and span Sensor modules are required to be calibrated annually.	
Typical response time		<30 s (T90)	
Specification temperature active	Measuring range	-4...122°F [-20...50°C] Please see the remarks section for the application notice for temperature sensor	
	Accuracy temperature	±7°C @ 23.5°C [13°F @ 74°F] Please see the Remarks section under Application Notice for more information about temperature accuracy	
Safety Data	Degree of protection NEMA/UL	NEMA 2	
	Agency Listing	cULus listed to UL2075, ULC-S588 cCSAus listed to C22.2 No. 61010-1-12, UL Std. No. 61010-1 (3rd Edition), harmonized under IEC/EN 61010-1 BTL listed No. BTL-30001	
	Pollution degree	2	
	Ambient humidity	15...90% RH continuous, 0...99% RH intermittent, non-condensing	
	Ambient temperature	-4...122°F [-20...50°C]	

Technical data

Materials	Housing	UL94 5VA
------------------	---------	----------

Remarks

Nominal voltage details All Belimo gas monitors, communication modules, and relay units can be powered by AC/DC 24 V. Under CSA/UL 61010-1 all gas monitors and communication modules are rated to AC 24 V only. Under ULC-S588 and UL 2075, all vehicle emissions gas monitors (CO, NO₂, CO + NO₂) are rated to AC/DC 24 V.

Nominal voltage range All Belimo gas monitors, communication modules, and relay units have a nominal voltage range of AC 17...28/DC 21...38 V (not UL or CSA-tested), AC/DC 20.4...26.4 V (UL-tested).

Power cable size and polarity Terminal blocks can accommodate one 14...20 AWG (2.5...0.5 mm²) or two 18...20 AWG (0.75...0.5 mm²) copper cables in the same terminal. Please take cable and transformer size into account to provide adequate voltage. Maintain the same polarity between devices at full power (AC/DC 24 V).

Communication cable size and polarity CAN bus and BACnet MS/TP communication cables should be 22...24 AWG (0.34...0.25 mm²), twisted-pair, shield-jacketed, low-capacitance stranded cable. Please consider the CAN bus baud rate (programmable setting No. 68) and BACnet the MS/TP baud rate (programmable setting No. 48) to provide working communications. For all communication wiring, maintain the same polarity and baud rate between all devices on the network.

Relay rating All relays used in Belimo gas monitors, communication modules, and relay units are rated for: SPDT, 5 A @ AC 125 V, non-inductive (UL/CSA tested), and SPDT, 4 A @ DC 24 V, non-inductive (not UL/CSA tested).

Application notice for temperature sensor All Belimo gas monitors and communication modules come with an internal temperature sensor. The purpose of this temperature sensor is to protect an enclosed parking garage from overheating or freezing, by activating relay 1. When using this feature, it is recommended to calibrate the temperature sensor to the ambient temperature (programmable setting No. 50), after the gas monitor has been powered for 24 hours. For freeze protection, it is recommended to set the temperature set point (programmable settings No. 55) at or over 40 °F [4°C].

Please note that this temperature sensor is located on the gas monitor printed circuit board (PCB). Therefore, it needs to be calibrated after 24 hours of normal operation to offset the heat generated by the PCB. It is not intended to be used as a room temperature sensor because of the limited accuracy and slow response time caused by its location on the PCB. This temperature sensor accuracy of ±13°F @ 74°F [7°C @ 23.5°C] has not been certified by UL.

Accuracy for gas monitors CO and NO₂ sensor accuracies are not certified by UL. Both accuracies were internally tested and validated in an environmental chamber and compared to a high-accuracy reference device (analyzer).

Application notice for gas sensors Intended applications include residential, light commercial, and light industrial. Non-intended applications include heavy commercial, heavy industrial, and hazardous locations.
 Vehicle emissions (CO, NO₂):
 Enclosed parking garages, loading docks, automotive maintenance facilities, truck maintenance facilities, fire stations, ambulance bays, boiler rooms, warehouses

Installation notes

Mounting height recommendations NO₂ mounting height recommendations in an enclosed parking garage are dependent on the types of vehicles being stored there and the ceiling height of the parking garage.

If a parking garage ceiling is higher than 4.5 m [15 ft"], then that is a good indicator that larger-sized vehicles such as trucks and heavy equipment will be stored there. Because a majority of larger vehicles have diesel engines, which release NO₂ as a byproduct, and have their exhaust released from above the vehicle, we recommend mounting NO₂ at half of the ceiling height, and/or above the diesel exhaust.

If a parking garage ceiling is lower than 15 feet (4.5 m), then that is a good indicator that larger-sized vehicles will not be stored there. In these applications it is recommended to place an NO₂ monitor at 3...7 feet (0.9...2.1 m) above the floor. The ideal position is at 5 feet (1.5 m), because if it is located at the correct height, it will be less likely to be damaged by passing cars and trucks, and it will also be at a convenient position for servicing.

Accessories

Replacement sensor modules	Description	Type
	Sensor module NO ₂ (Nitrogen Dioxide), 0...10 ppm,	R-G14
Electrical accessories	Description	Type
	Communication module, CAN bus, BACnet MS/TP, 1 relay, 2 analog outputs	C-22G-5A
	Communication module, CAN bus, BACnet MS/TP, 2 relays	C-22G-5B
	Communication module, CAN bus	C-22G-5C
	Relay unit, CAN bus, 4 relays	C-22G-50
	High-low mounting kit	A-22G-A14
	External visual alarm,	A-22G-A15
	External audible alarm	A-22G-A16
	Transformer, 50 VA	A-22G-A50
	Transformer, 100 VA	A-22G-A100
Mechanical accessories	Description	Type
	Splash proof housing	A-22G-A12
	Duct mount housing	A-22G-A13
	Calibration kit	A-22G-A22

Wiring Diagram

A Model Wiring

22G..-5A / C-22G-5A

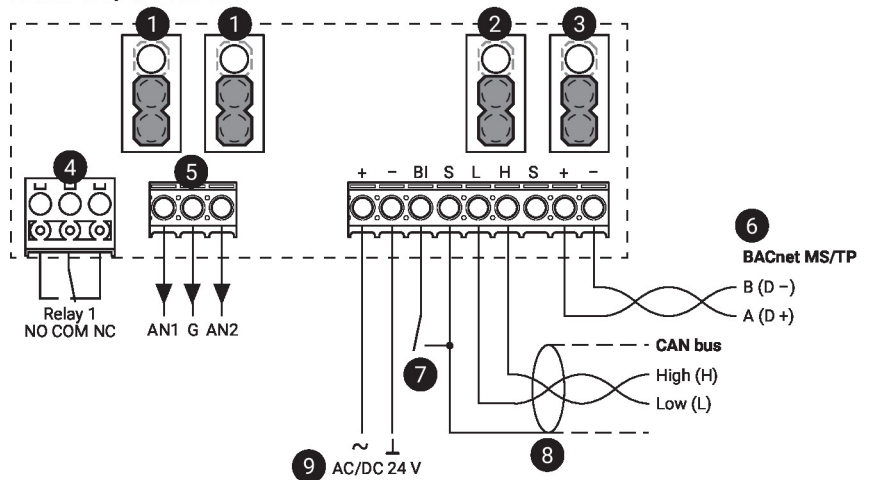

Wiring Diagram

B Model Wiring

22G..-5B / C-22G-5B

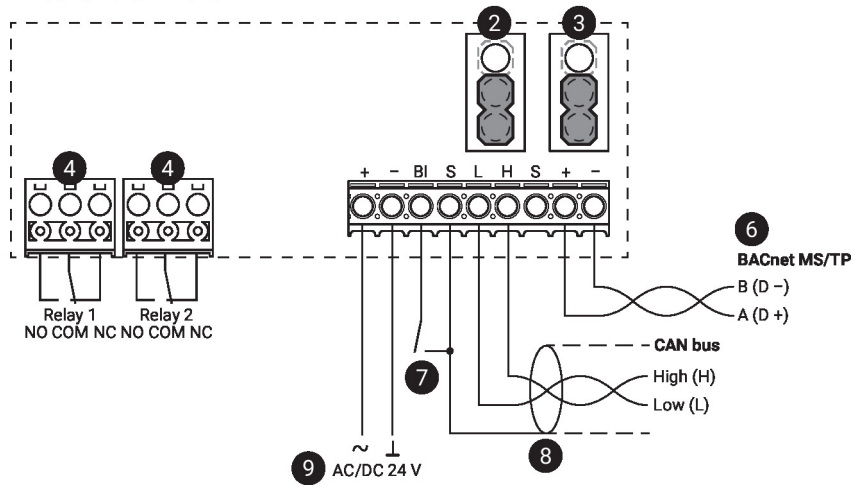

C Model Wiring

22G..-5C / C-22G-5C

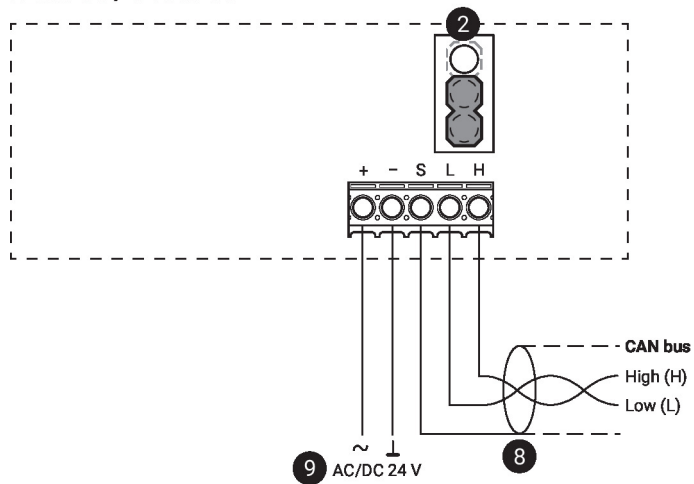

Wiring Diagram

- 1 **Analog outputs**
Down position: 2...10 V (factory setting)
Up position: 4...20 mA
- 2 **End of line (EOL) jumper: CAN bus**
Down position: Termination OFF (factory setting)
Up position: Termination ON (first and last unit only should have this jumper in the up position)
- 3 **End of line (EOL) jumper: MS/TP**
Down position: Termination OFF (factory setting)
Up position: Termination ON (first and last unit only should have this jumper in the up position)
- 4 **Relay switching contact**
- 5 **Analog output**
- 6 **Shield connected at the first unit only, at others only looped through**
- 7 **Binary input to limit switch**
- 8 **Shield connected at the first unit only, at others only looped through**
- 9 **No connection to the ground**

Wiring CAN bus

CAN bus Wiring

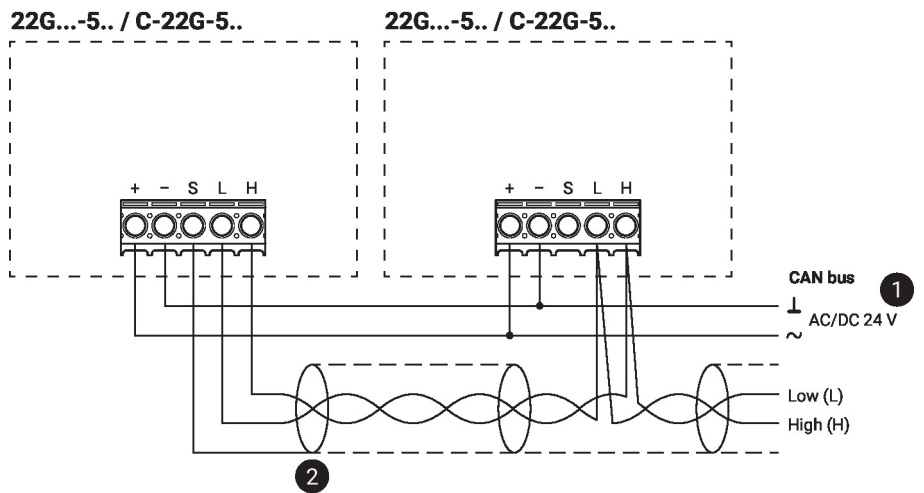

- 1 No connection to the ground
- 2 Shield connected at the first unit only, at others only looped through

Wiring Diagram

Wiring RS485 BACnet MS/TP

BACnet MS/ TP Wiring

22G..-5.. / C-22G-5..

22G..-5.. / C-22G-5..

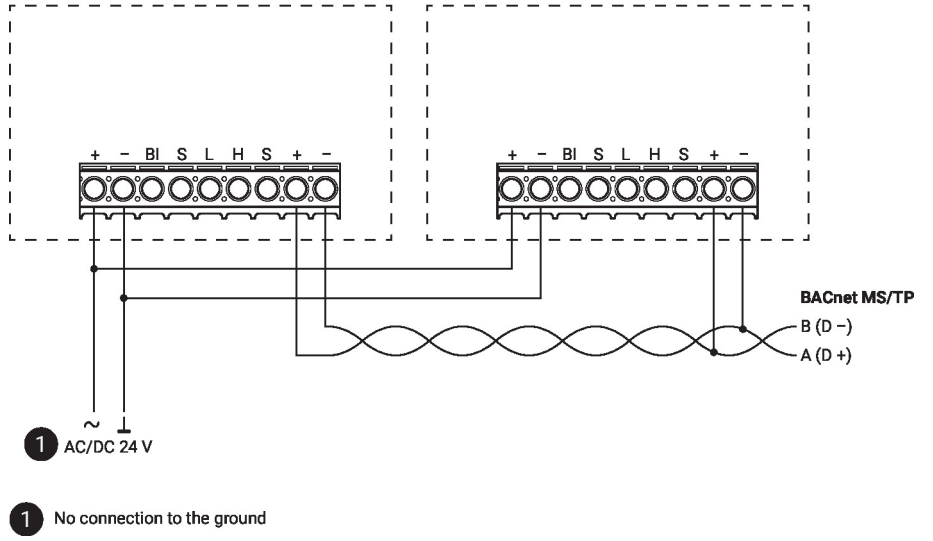

Dimensions

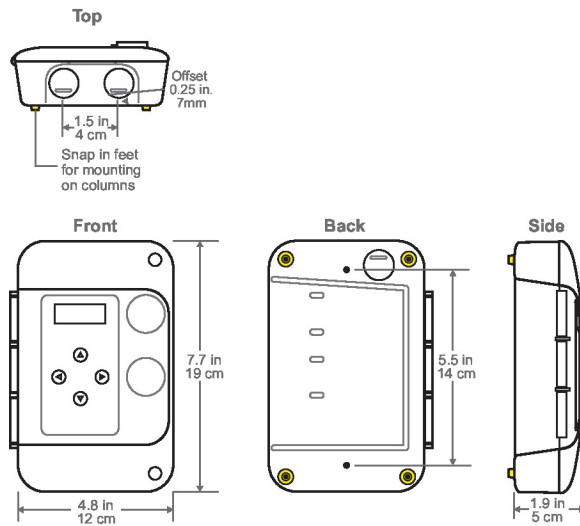

Type

- 22G14-5A
- 22G14-5B
- 22G14-5C

Weight

- 0.95 lb [0.43 kg]
- 0.95 lb [0.43 kg]
- 0.95 lb [0.43 kg]

Further documentation

- Installation instructions
- Operating instructions