

Thermal energy meter

Thermal energy meter provides precise flow and energy measurement in a heating or cooling system. Equipped with automatic temperature and glycol compensation that ensures reliable measurement. Optional PoE (Power over Ethernet) simplifies installation. Seamless integration via BACnet, Modbus and MP-Bus. Parameters can be easily set using NFC or a web server. Connection to Belimo Cloud supports remote Internet of Things metering and billing. NIST, SI, and BIPM-traceable.



5-year warranty



Type Overview

Type	DN	DN ["]	qp [GPM]	qs [GPM]	qi [GPM]	Δp [psi]	Additional features
22PE-5XUC	15	1/2	6.6	13.2	0.066	2.2	-
22PE-5XUD	20	3/4	11.0	22.0	0.110	1.7	-
22PE-5XUE	25	1	15.4	30.8	0.154	1.0	-
22PE-5XUF	32	1 1/4	26.4	52.8	0.264	2.0	-
22PE-5XUG	40	1 1/2	44.0	88.1	0.440	2.6	-
22PE-5XUH	50	2	66.0	132.1	0.660	3.2	-
22PE-5XUHH	50	2	100	132.1	1.0	7.3	-

qp: Nominal flow

qs: Highest flow

qi: Lowest flow

Δp: Pressure drop at nominal flow qp

Structure

Components The thermal energy meter 22PE-5U... consists of a logic and a sensor module. The logic module provides the power supply, the communication interface and the NFC connection of the energy meter.

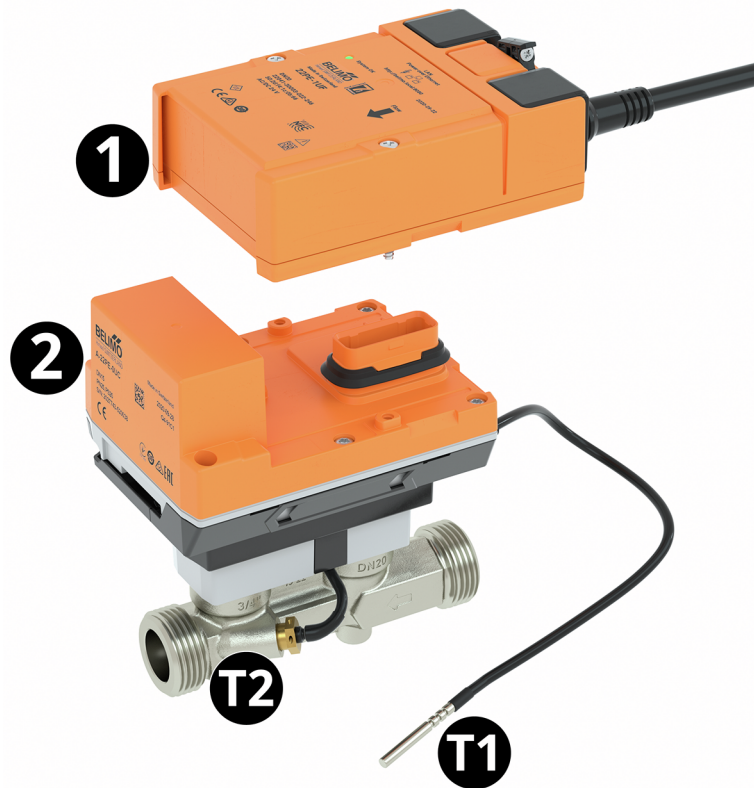

External temperature sensor T1
 Integrated temperature sensor T2
 Logic module 1
 Sensor module 2

Technical data

Electrical Data	Nominal voltage	AC/DC 24 V
	Nominal voltage frequency	50/60 Hz
	Nominal voltage range	AC 19.2...28.8 V / DC 21.6...28.8 V
	Power consumption AC	3 VA
	Power consumption DC	1.5 W
	Power consumption PoE	2.2 W
	Connection supply	cable 3 ft [1 m], 6x 0.75 mm ²
	Connection Ethernet	RJ45 socket
	Power over Ethernet PoE	DC 37...57 V IEEE 802.3af/at, Type 1, Class 3 11 W (PD13W)
	Conductors, cables	Power supply AC/DC 24 V: cable length <100 m, no shielding or twisting required Power supply PoE: shielded cables recommended
Annual energy consumption	With external energy supply 13.2 kWh	
Data bus communication	Communication	BACnet/IP BACnet MS/TP Modbus TCP Modbus RTU MP-Bus
	Communication note	M-Bus via Converter G-22PEM-A01
	Number of nodes	BACnet / Modbus see interface description MP-Bus max. 8 (16)

Technical data

Functional Data	Medium	Water Water-glycol mixture
	Configuration	via NFC, Belimo Assistant 2 via integrated web server
	Voltage output	1 x 0...10 V, 0.5...10 V, 2...10 V
	PN	25
	Body Pressure Rating	360 psi
	Pipe connection	External thread according to ISO 228-1
	Servicing	maintenance-free
	Inlet Length to Meet Specified Measurement Accuracy	≥ to 0 x DN (according to EN1434-4:2022)
Measuring Data	Measured values	Flow Temperature
	Measuring fluid	chilled or hot water, up to 60% glycol max (open loop/steam not allowed)
	Measuring principle	Ultrasonic flow measurement
Specification flow	Behavior at flow rate greater than q_s	Limitation at 2.5 x q_p
	Dynamic range $q_i:q_p$	1:100
	Measuring accuracy flow	±2% (of 20...100% q_p) @ 68°F [20°C] / glycol 0% vol.
	Measuring accuracy flow note	EN 1434 Class 2 @ 59...248°F [15...120°C]
Specification temperature passive	Temperature sensor	Pt1000 - EN 60751, 2-wire technology, inseparably connected Cable length external sensor T1: 3 m
Safety Data	Protection class IEC/EN	III, Protective Extra-Low Voltage (PELV)
	Degree of protection IEC/EN	IP54 Logic module: IP54 (with grommet A-22PEM-A04) Sensor module: IP65
	Degree of protection NEMA/UL	NEMA 2
	Pressure equipment directive	CE according to 2014/68/EU
	EMC	CE according to 2014/30/EU
	Certification IEC/EN	IEC/EN 60730-1:11 and IEC/EN 60730-2-15:10
	Quality Standard	ISO 9001
	Type of action	Type 1
	Rated impulse voltage supply	0.8 kV
	Pollution degree	3
	Ambient humidity	Max. 95% RH, non-condensing
	Ambient temperature	-22...122°F [-30...50°C]
	Fluid temperature	-20...120°C [-4...250°F] Frost protection must be guaranteed at fluid temperatures <2 °C [<36°F]
	Storage temperature	-40...176°F [-40...80°C]
	Materials	Cable
Fluid wetted parts		Brass nickel-plated, Brass, Stainless steel, PEEK, EPDM

Safety Notes



This device has been designed for use in stationary heating, ventilation and air-conditioning systems and must not be used outside the specified field of application, especially in aircraft or in any other airborne means of transport.

Outdoor applications: Only possible where (sea) water, snow, ice, sunlight or aggressive gases cannot interfere directly with the device and it can be guaranteed that the ambient conditions remain at all times within the thresholds according to the data sheet.

Only authorized specialists may carry out installation. All applicable legal or institutional installation regulations must be complied with during installation.

The device contains electrical and electronic components and must not be disposed of as household refuse. All locally valid regulations and requirements must be observed.

Product Features

Operating mode	<p>The thermal energy meter consists of a flow measuring section, evaluation electronics and two temperature sensors. One temperature sensor is integrated in the flow sensor, the other temperature sensor is installed as an external sensor.</p> <p>The device determines the thermal energy supplied to the heat exchanger or coil from the flow and the temperature difference between supply and return.</p> <p>The thermal energy meter can be operated as a heat meter, cooling meter or heat/cooling meter. In addition, it can be installed either in the return or in the supply of the system. The corresponding application must be set via NFC when activated with Belimo Assistant 2.</p>
Calibration certificate	<p>A calibration certificate is available in the Belimo Cloud for each thermal energy meter. If required, this can be downloaded as a PDF with Belimo Assistant 2 or via the Belimo Cloud frontend.</p>
Energy metering	<p>The energy meter can be configured as a combined heat/cooling meter via NFC and Belimo Assistant 2.</p>
Flow measurement	<p>The thermal energy meter measures the current flow rate every 0.1 s in mains operation.</p>
Power calculation	<p>The thermal energy meter calculates the current thermal power based on the current flow rate and the measured temperature difference.</p>
Invoicing energy consumption	<p>The energy consumption data can be read out as follows:</p> <ul style="list-style-type: none"> - Bus - Cloud API - Belimo Cloud Account of the device owner - Belimo Assistant 2 - Integrated web server
Belimo cloud	<p>The "Terms of Use for Belimo Cloud Services" in their currently valid version apply to the use of cloud services.</p> <p>Note: The connection to the Belimo Cloud is permanently available. Activation takes place via web server or Belimo Assistant 2.</p>
PoE (Power over Ethernet)	<p>If necessary, the thermal energy meter can be supplied with power via the Ethernet cable. This function can be enabled via Belimo Assistant 2.</p> <p>DC 24 V (max. 8 W) is available at wires 1 and 2 for power supply of external devices (e.g., actuator or active sensor).</p> <p>Caution: PoE may only be enabled if an external device is connected to wires 1 and 2 or if wires 1 and 2 are insulated!</p>
Commissioning report	<p>Once commissioning has been completed, a commissioning report is available via the web server or Belimo Assistant 2, in which all settings and basic data are presented in a clear and structured manner. The commissioning report can be saved as a PDF file.</p>

Product Features

Pressure drop

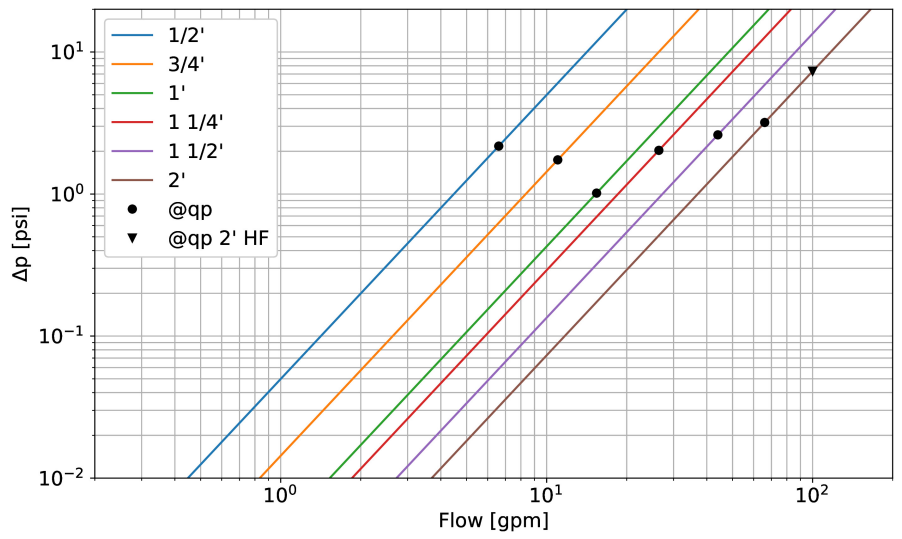

Measuring accuracy

Measuring accuracy for water (glycol 0% vol.):

±2% (@ 20...100% qp)

At a temperature range of 15...120 °C.

Measuring accuracy for water + glycol (glycol 0...60% vol.)

±5% (@ 20...100% qp) ±0.01 qp, but not more than 30% of q (@ qi...20% qp)

At a temperature range of -20...120°C.

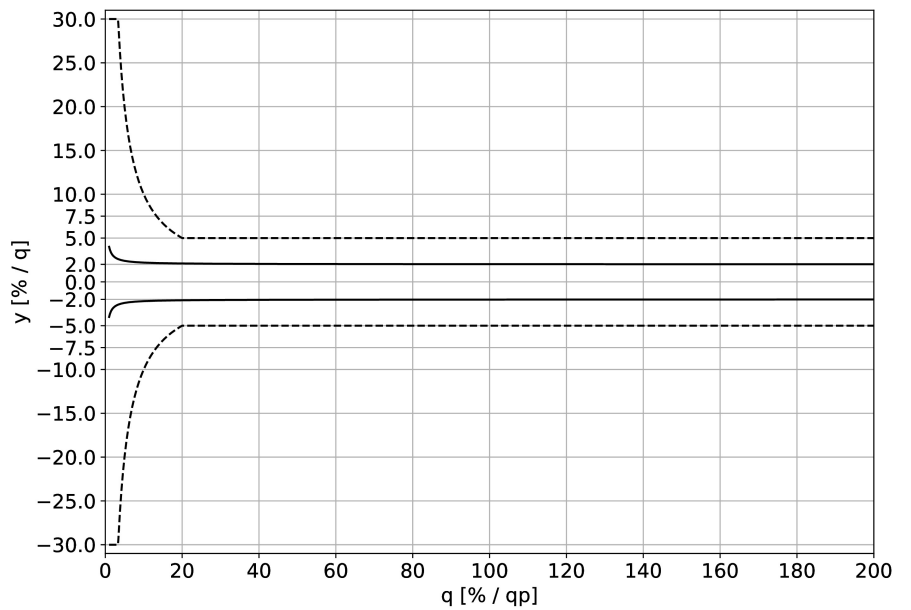

Operation

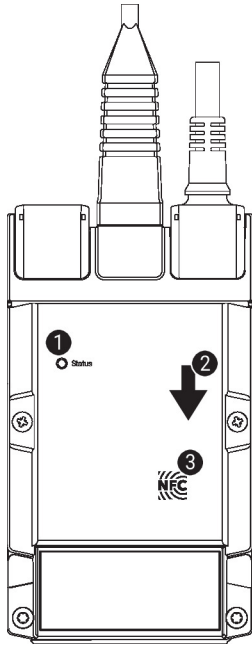

1 LED display green

- On: Device starting up
- Flashing: In operation (Power ok)
- Off: No power

2 Flow direction

3 NFC interface

Installation notes

Permissible installation orientation

The sensor can be installed upright to horizontal. The sensor may not be installed in a hanging position.

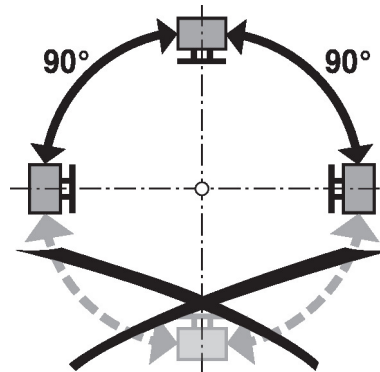

Installation in return

Installation in the return is recommended.

Dimensioning

The thermal energy meter is dimensioned to the nominal flow (q_p).
The flow rate may increase to the highest flow (q_s) for a short time (<1h/day).

Installation notes

Inlet section There are no requirements for straight inlet sections prior to the flow sensor. Product has been tested to and fulfills the requirements of EN1434-4:2022

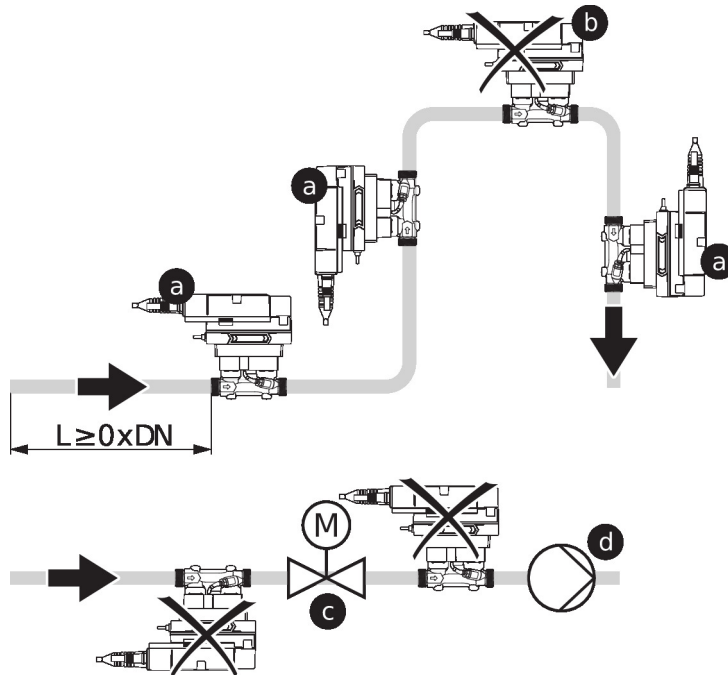

Water quality requirements The water quality requirements specified in VDI 2035 must be adhered to.

Servicing Thermal energy meter are maintenance-free.

Before any service work on the thermal energy meter is carried out, it is essential to isolate the thermal energy meter from the power supply (by unplugging the electrical cables if necessary). Any pumps in the part of the piping system concerned must also be switched off and the appropriate slide valves closed (allow all components to cool down first if necessary and always reduce the system pressure to ambient pressure level).

The system must not be returned to service until the thermal energy meter has been correctly reassembled in accordance with the instructions and the pipeline has been refilled by professionally trained personnel.

Flow direction The direction of flow, specified by an arrow on the housing, is to be complied with, since otherwise the flow rate will be measured incorrectly.

Avoiding cavitation To avoid cavitation, the system pressure at the outlet of the thermal energy meter must be a minimum of 14.5 psi [1.0 bar] at qs (highest flow) and temperatures up to 195°F [90°C]. At a temperature of 250°F [120°C] the system pressure at the outlet of the thermal energy meter must be at least 36.3 psi [2.5 bar].

Cleaning of pipes Before installing the thermal energy meter, the circuit must be thoroughly rinsed to remove impurities.

Prevention of stresses The energy meter must not be subjected to excessive stress caused by pipes or fittings.

Parts included

Description	Type
Grommet for RJ connection module with clamp	A-22PEM-A04
Thermowell (fabricated) Stainless steel, 2" [50 mm], 1/2" NPT, SW=0.94"	A-22PE-A15

Accessories

Optional accessories	Description	Type
	T-piece with thermowell DN 15	A-22PE-A09
	Insulation shell for thermal energy meter DN 15...25	A-22PEM-A01
	Converter M-Bus	G-22PEM-A01

Accessories

	Description	Type
	T-piece with thermowell DN 20	A-22PE-A10
	T-piece with thermowell DN 25	A-22PE-A11
	T-piece with thermowell DN 32	A-22PE-A12
	Insulation shell for thermal energy meter DN 32...50	A-22PEM-A02
	T-piece with thermowell DN 40	A-22PE-A13
	T-piece with thermowell DN 50	A-22PE-A14
Tools	Description	Type
	Belimo Assistant Link Bluetooth and USB to NFC and MP-Bus converter for configurable and communicative devices	LINK.10

Wiring Diagram



Supply from isolating transformer.

The wiring of the line for BACnet MS/TP / Modbus RTU is to be carried out in accordance with applicable RS485 regulations.

Modbus / BACnet: Supply and communication are not a galvanic dry contact. COM and the ground of the devices must be connected.

Sensor connection: An additional sensor can optionally be connected to the thermal energy meter. This can be a passive resistance sensor Pt1000, Ni1000, NTC10k (10k2), an active sensor with output DC 0...10 V or a switching contact. Thus the analogue signal of the sensor can be easily digitised with the thermal energy meter and transferred to the corresponding bus system.

Analog output: An analog output is available on the thermal energy meter. This can be selected as DC 0...10 V, DC 0.5...10 V or DC 2...10 V. For example, the flow rate or the temperature of the temperature sensor T1 / T2 can be output as an analog value.

Wire colors:

- 1 = black
- 2 = red
- 3 = white
- 5 = orange
- 6 = pink
- 7 = grey

Functions:

- 1 = Com
- 2 = AC/DC 24 V
- 3 = Sensor (optional)
- 5 = 0...10 V, MP-Bus
- C1 = D- (wire 6)
- C2 = D+ (wire 7)

AC/DC 24 V, output signal

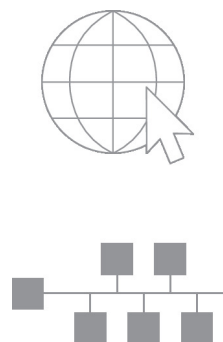
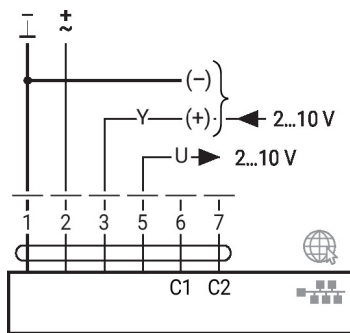

Connection of a notebook for parameterisation manual control via Rj45. Optional connection via RJ45 (direct connection to notebook / connection via Intranet or Internet) for access to the integrated web server

Wiring Diagram

BACnet MS/TP / Modbus RTU

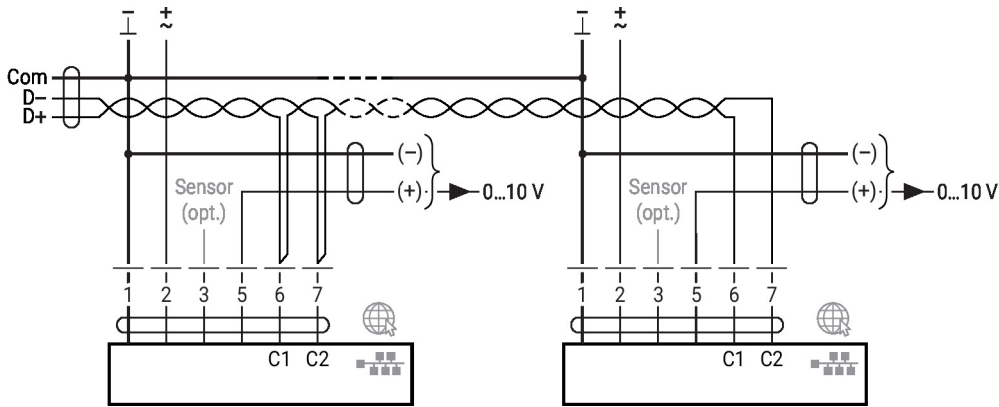

BACnet/IP / Modbus TCP

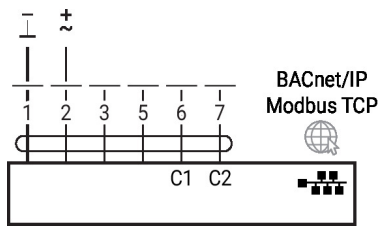

PoE with BACnet/IP / Modbus TCP

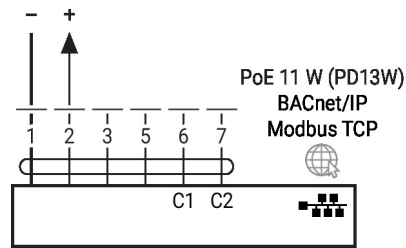

MP-Bus, supply via 3-wire connection

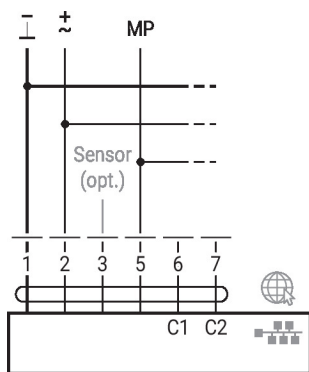

MP-Bus via 2-wire connection, local power supply

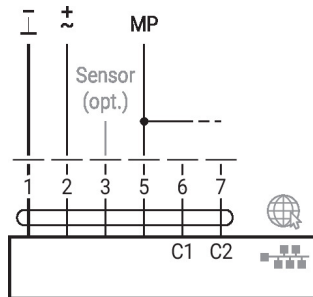

M-Bus with converter

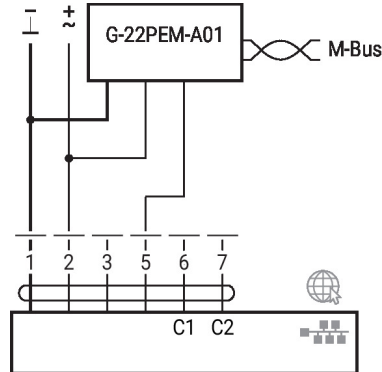

M-Bus with converter in parallel mode with BACnet/IP / Modbus TCP

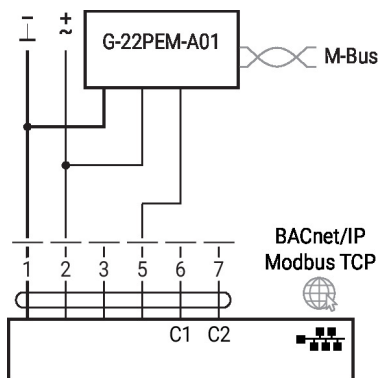

M-Bus with converter in parallel mode with PoE with BACnet/IP / Modbus TCP

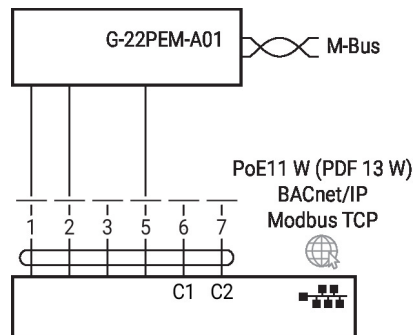

Wiring Diagram

M-Bus parallel Modbus RTU or BACnet MS/TP

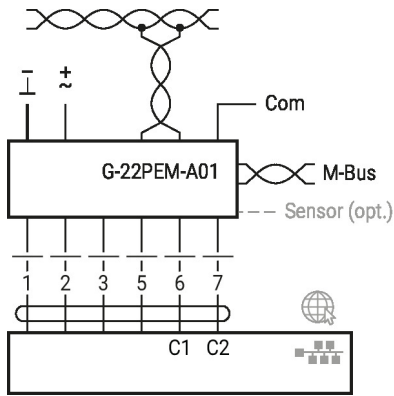

Connection with active sensor

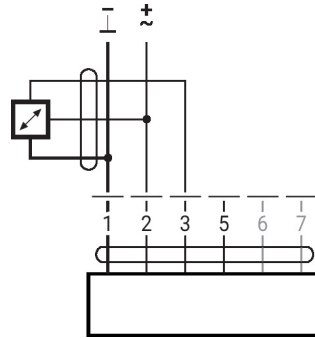

Connection with switching contact

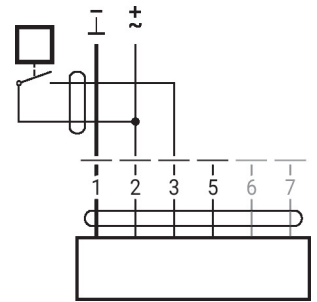

Connection with passive sensor

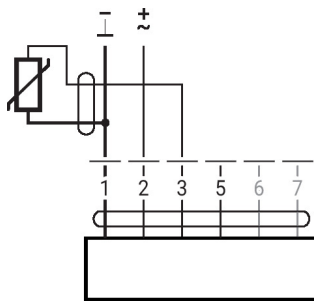

Dimensions

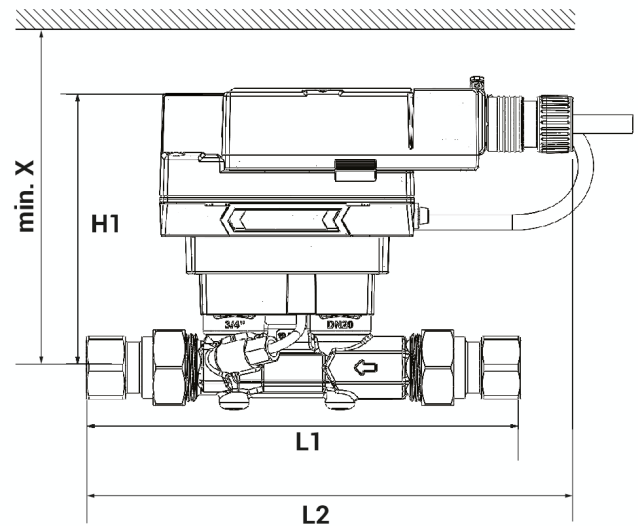
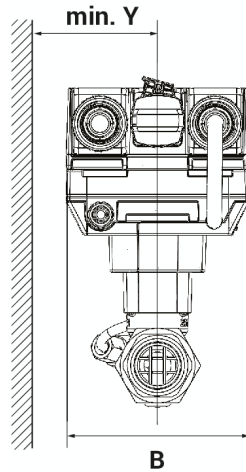

Type	DN	DN ["]	L1 [mm]	L1 ["]	L2 [mm]	L2 ["]	B [mm]	B ["]	H1 [mm]	H1 ["]	X [mm]	X ["]	Y [mm]	Y ["]	Weight
22PE-5XUC	15	1/2	184	7.2	230	-	230	9.0	136	5.3	206	8.1	85	3.3	2.8 lb [1.3 kg]
22PE-5XUD	20	3/4	213	8.4	230	-	230	9.0	136	5.3	206	8.1	85	3.3	3.2 lb [1.5 kg]
22PE-5XUE	25	1	225	8.9	230	-	230	9.0	140	5.5	210	8.2	85	3.3	3.6 lb [1.6 kg]
22PE-5XUF	32	1 1/4	242	9.5	230	-	230	9.0	143	5.6	213	8.3	85	3.3	3.9 lb [1.8 kg]
22PE-5XUG	40	1 1/2	249	9.8	230	-	230	9.0	147	5.8	217	8.5	85	3.3	4.6 lb [2.1 kg]

Dimensions

Type	DN	DN ["]	L1 [mm]	L1 ["]	L2 [mm]	L2 ["]	B [mm]	B ["]	H1 [mm]	H1 ["]	X [mm]	X ["]	Y [mm]	Y ["]	Weight
22PE-5XUH	50	2	213	8.4	230	-	230	9.0	152	5.9	222	8.7	85	3.3	5.6 lb [2.5 kg]
22PE-5XUHH	50	2	213	8.4	230	-	230	9.0	152	5.9	222	8.7	85	3.3	5.6 lb [2.5 kg]

Further documentation

- Overview MP Cooperation Partners
- Description Data-Pool Values
- BACnet Interface description
- Modbus Interface description
- Installation instructions
- Operating instructions