

# Belimo Gas Monitors



## Operating Manual



Discover the advantages  
[www.belimo.com](http://www.belimo.com)

**BELIMO**<sup>®</sup>

# Table of contents

<b>1.0</b>	<b>General description</b>	<b>4</b>
1.1	Warnings	5
1.2	Applications	6
1.3	Features	7
1.4	Specifications	7
<b>2.0</b>	<b>Model selection guide</b>	<b>8</b>
<b>3.0</b>	<b>Installation</b>	<b>11</b>
3.1	Placement	11
3.2	Wiring	12
3.3	Start Up Check List	15
3.4	Warm-up Time	17
3.5	Broadband Refrigerant Monitor Zeroing Procedure and Refrigerant Selection	17
<b>4.0</b>	<b>Operation</b>	<b>18</b>
4.1	Home Screen Display	18
4.2	Default Alarm Set Points	19
4.3	Button Basics	20
4.4	Reset Menu Settings	20
4.5	Password Protection	21
4.6	All Menu Settings	22
4.7	Sequence of Operations	33
<b>5.0</b>	<b>Network configuration (CAN bus)</b>	<b>35</b>
5.1	Zoned Ventilation	35
5.2	Transmit and Receive Messages	35
5.3	Practical Application	38
5.4	Binary Input	41
5.5	Fault Alarms	41
5.6	Equipment Controlled from Dedicated Locations	42
5.7	Equipment Controlled Directly from the Gas Monitors	42
5.8	Relay Outputs	42
<b>6.0</b>	<b>Network configuration (BACnet MS/TP)</b>	<b>43</b>
6.1	Menu Settings: BACnet MS/TP	43
6.2	Protocol Implementation Conformance Statement (PICS): BACnet MS/TP	45
<b>7.0</b>	<b>Analog output configuration</b>	<b>46</b>
7.1	Default Analog Outputs	46
7.2	Customized Analog Outputs	46
7.3	Practical Application	49

<b>8.0</b>	<b>Maintenance</b>	<b>53</b>
8.1	Calibration: Overview	53
8.2	Calibration: Required Equipment	53
8.3	Calibration: CO, NO <sub>2</sub> , NH <sub>3</sub> , CH <sub>4</sub> , C <sub>3</sub> H <sub>8</sub> , H <sub>2</sub> , H <sub>2</sub> S, CL <sub>2</sub> , O <sub>2</sub>	53
8.4	Calibration: CO <sub>2</sub>	54
8.5	Calibration: Broadband Refrigerant	55
8.6	Sensor Module: Sensing Technology	56
8.7	Sensor Module: Installation and Replacement	57
8.8	Sensor Module: Expected Life Span and End of Life	59
8.9	Fault Monitoring	60

# 1.0 General description

## Safety Note

This operating manual provides all of the required information to properly install, operate, and maintain a Belimo gas monitoring system. Installation, operation, and maintenance not in accordance with this manual can result in a hazardous situation or harm. Please read and understand this document before installing and servicing your own system.

## General Description

Closely monitoring the quality of air that we breathe improves our well-being. Belimo gas monitors keep people safe and conserve energy by allowing for on demand ventilation as opposed to continuous or scheduled ventilation.

All Belimo gas monitors are factory calibrated and can detect two different gases simultaneously. They feature three alarm levels, an internal horn and strobe alarm, and CAN bus communication that allows for standalone operation. Select models provide analog outputs, relays, and BACnet MS/TP, to control external equipment directly and to tie into a building management system (BMS). All gas monitors are wired daisy chain, allowing up to 32 devices per chain, and can be programmed to zone ventilation on the same daisy chain network.

Accessories include replacement sensor modules, calibration kits, external horn and strobe alarms, communication modules, relay units, power transformers, remote enclosures, duct and splash proof enclosures, and security screws. All Belimo gas monitoring products come with a five-year warranty and all sensor modules come with a one-year warranty.



## 1.1 Warnings

- Belimo gas monitors are designed to monitor gas leaks, where under normal conditions the targeted gases are not present in high concentrations in the space.
- All devices must be powered down during installation and maintenance.
- Belimo gas monitors must be installed, operated, and maintained in accordance with all applicable laws and regulations. To ensure safe operation, please read and understand this document before installing, operating, or maintaining any Belimo gas monitors.
- Take caution for electrostatic discharge (ESD) during installation, service, and when replacing sensor modules.
- Install devices in locations that are easily serviceable, safely accessible, and protected from physical damage to cars, forklifts and any other equipment.
- To prevent electrical interference, keep all devices and wiring away from mercury vapor lights, variable speed drives, and radio repeaters.
- To prevent mechanical interference, keep all devices and wiring away from electrical shock, continuous mechanical shock, and vibration.
- Substances to avoid include silicon vapor, paint fumes, and any other solvents which can destroy or affect the gas monitor's performance.
- Do not paint any gas monitors or accessories.
- Protect gas monitors from continuous exposure to water by installing them in a splash proof enclosure. (A-22G-A12)
- For all applications, it is recommended to install more than one device to limit the chance of failures.
- When installing methane, propane, and hydrogen gas monitors, it is required to have more than one gas monitor installed in each room.
- All Belimo gas monitors require a specific warm up time for their sensor modules to operate normally.
- Belimo gas monitors are required to be calibrated annually or more frequently as specified. Upon calibration, it is highly recommended to verify proper operation of the system.
- Belimo gas monitors are designed for use in stationary systems and must not be used outside of this specified field of application. Using them for any other purpose may result in exposure to hazardous gas, causing serious injury or death. Unauthorized modifications are prohibited. Caution must be observed when used in relation with any equipment, that in case of a failure, may threaten humans, animals or assets.
- Intended applications include commercial and light industrial. Non intended applications include industrial, or hazardous locations.
- Belimo gas monitors contain electronic components and must not be disposed of as household refuse. All locally valid regulations and requirements must be observed.
- Failure to follow this manual and other applicable product documentation may result in property damage, serious injury, or death. It may also compromise the gas monitor performance and void the product's warranty.



**WARNING:**  
DO NOT PAINT  
THE MONITOR

## 1.2 Applications

- **Commercial Applications**
  - Apartment buildings
  - Condominium buildings
  - Data centers
  - Hotels
  - Medical facilities
  - Office buildings
  - Restaurants
  - Retail
  - Service centers
  - Warehouses
- **Light Industrial Applications**
  - Food processing plants
  - Textile plants
  - Vehicle and machinery facilities
  - Warehouses
- **CO, NO<sub>2</sub>**
  - Ambulance bays
  - Automotive maintenance facilities
  - Boiler rooms
  - Enclosed parking garages
  - Fire stations
  - Loading docks
  - Truck maintenance facilities
  - Warehouses
- **CO<sub>2</sub>**
  - 0...2000 ppm
    - Classrooms
    - Conference rooms
    - Warehouses
  - 0...5000/10000 ppm
    - Breweries
    - Compressor rooms
    - Greenhouses
    - Indoor grow farms
    - Mechanical rooms
    - Medical gas storage
- **NH<sub>3</sub>, CH<sub>4</sub>, C<sub>3</sub>H<sub>8</sub>, H<sub>2</sub>, H<sub>2</sub>S, CL<sub>2</sub>, O<sub>2</sub> Leak, O<sub>2</sub> Depletion (Ar, He, N)**
  - Cold storage (NH<sub>3</sub>)
  - Compressor rooms (NH<sub>3</sub>)
  - Food processing plants (NH<sub>3</sub>)
  - Ice rinks (NH<sub>3</sub>)
  - Mechanical rooms (NH<sub>3</sub>)
  - Landfills (NH<sub>3</sub>, H<sub>2</sub>S, CH<sub>4</sub>)
  - Recycle centers (NH<sub>3</sub>, H<sub>2</sub>S)
  - Water and wastewater treatment plants (NH<sub>3</sub>, H<sub>2</sub>S, CL<sub>2</sub>)
  - Boiler rooms (CH<sub>4</sub>)
  - Natural gas leaks (CH<sub>4</sub>)
  - Commercial kitchens (CH<sub>4</sub>, C<sub>3</sub>H<sub>8</sub>)
  - Laboratories (C<sub>3</sub>H<sub>8</sub>, O<sub>2</sub> Leak, O<sub>2</sub> Dep.)
  - Warehouses (C<sub>3</sub>H<sub>8</sub>, H<sub>2</sub>)
  - Loaded lead acid battery charging stations (H<sub>2</sub>)
  - Swimming pool mechanical rooms (CL<sub>2</sub>)
  - Medical gas storage (O<sub>2</sub> Leak, O<sub>2</sub> Dep.)
  - Welding facilities (O<sub>2</sub> leak, O<sub>2</sub> Dep.)
- **Refrigerants**
  - Compressor rooms
  - Grocery stores
  - Mechanical rooms

## 1.3 Features

- Direct control through on board relays and configurable analog outputs
- Monitors two gases in one device
- Standalone operation through CAN bus
- Integration into a BMS through BACnet MS/TP
- Three adjustable automatic or manual reset alarm levels
- Internal horn and strobe alarm
- Factory calibrated and field replaceable sensor modules
- Screen display, four-button keypad, and optional password protection
- Binary input for external switch or input
- BACnet Testing Laboratories (BTL) listed smart sensor

## 1.4 Specifications

- Rated voltage:
  - ~ 24 V, 50/60 Hz, 5 VA
  - = 24 V, 4.0 W
  - Use a Class 2 Power Supply
  - Overvoltage Category III (OVC III)
- Operating voltage range:
  - ~ 20...25 V
  - = 22...34 V
- Operating temperature range:
  - -4°F...+104°F [-20°C...+50°C]: Broadband refrigerant
  - -4°F...+122°F [-20°C...+50°C]: CO, NO<sub>2</sub>, CO<sub>2</sub> (0...5000/10000 ppm), NH<sub>3</sub>, H<sub>2</sub>S, CL<sub>2</sub>, O<sub>2</sub> Leak, O<sub>2</sub> Dep.
  - 14°F...+122°F [-10°C...+40°C]: CH<sub>4</sub>, C<sub>3</sub>H<sub>8</sub>, H<sub>2</sub>
  - 32°F...+122°F [0°C...+40°C]: CO<sub>2</sub> (0...2000 ppm)
- Operating humidity range:
  - 15...90% RH continuous, 0...99% RH intermittent, non-condensing
- Operating altitude range:
  - Calibration verification is recommended above 2000 ft [610 m]
  - Maximum altitude 6560 ft [2000 m]
- Relays:
  - SPDT, 5A @ AC 125 V / 4A @ DC 24 V, non-inductive
  - 1x relay available on all -A models
  - 2x relays available on all -B models
- Analog outputs:
  - 2...10 V or 4...20 mA default, scalable, min/max selectable
  - 2x analog outputs available on all -A models
- Binary input:
  - 1x binary input on all -A and -B models
- Agency listings:
  - cCSAus listed to C22.2 No. 61010-1-12, UL Std. No. 61010-1 (3rd Edition), harmonized under IEC/EN 61010-1
  - UL acc. to ANSI/UL 2075 and CAN/ULC 588 for the following products: 22G02-5A, 22G02-5B, 22G02-5C, 22G14-5A, 22G14-5B, 22G14-5C, 22G0214-5A, 22G0214-5B, 22G0214-5C
- Housings:
  - Flame resistant polycarbonate ABS plastic enclosure
  - UL94 5 VA
  - NEMA 2 / IP44 (CO, NO<sub>2</sub>, NH<sub>3</sub>, H<sub>2</sub>S, CL<sub>2</sub>, O<sub>2</sub>)
  - IP 20 (CO<sub>2</sub>, CH<sub>4</sub>, C<sub>3</sub>H<sub>8</sub>, H<sub>2</sub>, Broadband refrigerant)
  - For indoor use
  - Pollution degree 2

## 2.0 Model selection guide

### Gas Monitors

22	G	0214	-5	A
<b>Power</b> 22 = Active	<b>Gas Monitoring</b>	<b>Measured Values</b> 02 = Carbon monoxide (CO) 0214 = Carbon monoxide (CO) and Nitrogen dioxide (NO <sub>2</sub> ) 03 = Carbon monoxide null hydrogen (CO null H <sub>2</sub> ) 04 = Ammonia (NH <sub>3</sub> ) 05 = Methane/Natural gas (CH <sub>4</sub> ) 06 = Propane (C <sub>3</sub> H <sub>8</sub> ) 08 = Hydrogen (H <sub>2</sub> ) 14 = Nitrogen dioxide (NO <sub>2</sub> ) 15 = Carbon dioxide (CO <sub>2</sub> ) 16 = Hydrogen sulfide (H <sub>2</sub> S) 17 = Chlorine (Cl <sub>2</sub> ) 21 = Broadband refrigerant (R11, R22, R23, R32, R125, R134a, R404A, R407A, R407C, R407F, R410A, R448A, R449A, R452A, R454B, R455A, R507, R513A, R1233zd, R1234yf, R1234ze) 22 = Oxygen (O <sub>2</sub> ) Leak 23 = Oxygen (O <sub>2</sub> ) depletion (Argon: Ar, Helium: He, Nitrogen: N <sub>2</sub> )	<b>Region</b> -5 = Americas	<b>Signal Type</b> A = CAN bus, BACnet MS/TP, 1 Binary input, 1 Relay, 2 Analog Outputs B = CAN bus, BACnet MS/TP, 1 Binary input, 2 Relays C = CAN bus



22G0214-5A

### Sensor Modules

R	-G	02
<b>Replacement</b>	<b>Gas Monitoring</b>	<b>Measured Values</b> 02 = Carbon monoxide (CO) 03 = Carbon monoxide null hydrogen (CO null H <sub>2</sub> ) 04 = Ammonia (NH <sub>3</sub> ) 05 = Methane/Natural gas (CH <sub>4</sub> ) 06 = Propane (C <sub>3</sub> H <sub>8</sub> ) 08 = Hydrogen (H <sub>2</sub> ) 14 = Nitrogen dioxide (NO <sub>2</sub> ) 15-00x = Carbon dioxide (CO <sub>2</sub> ) 16 = Hydrogen sulfide (H <sub>2</sub> S) 17 = Chlorine (Cl <sub>2</sub> ) 22 = Oxygen (O <sub>2</sub> ) Leak 23 = Oxygen (O <sub>2</sub> ) depletion (Argon: Ar, Helium: He, Nitrogen: N <sub>2</sub> )



R-G02

APPLICATION	GAS TYPE	ABBREVIATION	GAS TYPE IDENTIFICATION NUMBER	MEASURING RANGE
<b>Vehicle Emissions</b>	Carbon monoxide	CO	02	0...250 ppm
		CO Null H <sub>2</sub>	03	0...250 ppm
	Nitrogen dioxide	NO <sub>2</sub>	14	0...10 ppm
<b>Indoor Air Quality</b>	Carbon dioxide	CO <sub>2</sub>	15-003	0...2000 ppm
			15-005	0...5000 ppm
			15-006	0...10000 ppm
<b>Combustible and Toxic Gases</b>	Ammonia	NH <sub>3</sub>	04	0...250 ppm
	Methane/Natural gas	CH <sub>4</sub>	05	0...50% LEL
	Propane	C <sub>3</sub> H <sub>8</sub>	06	0...50% LEL
	Hydrogen	H <sub>2</sub>	08	0...50% LEL
	Hydrogen sulfide	H <sub>2</sub> S	16	0...50 ppm
	Chlorine	CL <sub>2</sub>	17	0...10 ppm
	Oxygen leak	O <sub>2</sub> Leak	22	0...50% O <sub>2</sub>
	Oxygen depletion (Argon: Ar, Helium: He, Nitrogen: N <sub>2</sub> )	O <sub>2</sub> Dep.	23	0...50% O <sub>2</sub>
<b>Refrigerant Gas Leak Detection</b>	Broadband refrigerant	Ref.	21	0...2000 ppm
	R11, R22, R23, R32, R125, R134a, R404A, R407A, R407C, R407F, R410A, R448A, R449A, R452A, R454B, R455A, R507, R513A, R1233zd, R1234yf, R1234ze			

## Communication Modules

C	-22	G	-5	B
<b>Communication</b>	<b>Power</b> 22 = Active	<b>Gas Monitoring</b>	<b>Region</b> -5 = Americas	<b>Signal Type</b> A = CAN bus, BACnet MS/TP, 1 Binary input, 1 Relay, 2 Analog outputs B = CAN bus, BACnet MS/TP, 1 Binary input, 2 Relays C = CAN bus



C-22G-5B

## Relay Units

C	-22	G	-5	0
<b>Power</b> 22 = Active	<b>Gas Monitoring</b>	<b>Region</b> -5 = Americas	<b>Signal Type</b> 0 = 4 Relays	



C-22G-50

## Miscellaneous Accessories

A	-22	G	-A	..
<b>Accessory</b>	<b>Power</b> 22 = Active	<b>Gas Monitoring</b>	<b>Accessory Type</b> 08 = Broadband refrigerant calibration regulator, cap, and hose 09 = Broadband refrigerant calibration cap and hose 12 = Splash proof enclosure 13 = Duct mount enclosure 14 = Enclosure to remotely mount one sensor 15 = External strobe alarm 16 = External horn alarm 22 = Calibration regulator, cap, and hose 23 = Calibration cap and hose 24 = Security screws 50 = Power transformer: 50 VA 100 = Power transformer: 100 VA	



# 3.0 Installation

## 3.1 Placement

All Belimo gas monitors have a coverage area and a recommended mounting height. Please see below for more details.

### Coverage area

The recommended coverage area is based on how long the target gas diffuses from the source to reach the gas monitor. Using the recommended coverage area, every gas monitor has a typical response time represented as a T90 value. The T90 value means that within x seconds, the gas monitor will accurately read 90% or more of the true gas reading.

The coverage area is limited by any obstructions to the gas monitor, such as walls, stairs, elevators, shelving with solid fill, tool chests, etc. The gas monitor must "see" the area of coverage; if not the coverage area is reduced, and additional gas monitors are required. When placing gas monitors, avoid drafts, obstacles, aerosols, silicones, and place them in the center of their area of coverage as much as possible.

- For monitoring **CO** and **NO<sub>2</sub>** gases, the **maximum radius of coverage is 50 feet (15 meters)**, and the maximum area of coverage is 7800 square feet (700 square meters).
- For monitoring **all other gases**, place the gas monitor as close to the leak as possible, avoiding electrical and mechanical shock. The **maximum radius of coverage is 30 feet (10 meters)**, and the maximum area of coverage is 2800 square feet (300 square meters).

### Mounting height

The recommended mounting height is based on the density of the target gas relative to air.

- For gases **lighter than air**:  
Ammonia (NH<sub>3</sub>), Methane/Natural gas (CH<sub>4</sub>), Hydrogen (H<sub>2</sub>):  
Install at 1 to 3 feet (0.3 to 0.9 meters) from the ceiling
- For gases **similar to air**:  
Carbon monoxide (CO), Carbon dioxide (CO<sub>2</sub>), Oxygen leak (O<sub>2</sub> leak), Oxygen depletion (O<sub>2</sub> dep.) to monitor Argon: Ar, Helium: He, Nitrogen: N<sub>2</sub>:  
Install at 3 to 7 feet (1 to 2 meters) from the floor.

Nitrogen dioxide (NO<sub>2</sub>): If diesel exhaust is **under** vehicles, or if the **ceiling height is 15 feet or less**, install at 3 to 7 feet (1 to 2 meters) from the floor.

Nitrogen dioxide (NO<sub>2</sub>): If diesel exhaust is **above** vehicles, or if the **ceiling height is above 15 feet**, install at half the ceiling height or slightly above the exhaust stack.

- For gases **heavier than air**:  
Propane (C<sub>3</sub>H<sub>8</sub>), Hydrogen sulfide (H<sub>2</sub>S), Chlorine (CL<sub>2</sub>), Refrigerants:  
Install at 1 to 2 feet (0.3 to 0.5 meters) from the floor.

### Installation on round columns

To install gas monitors on round columns or non-flat surfaces, use the four plastic yellow feet provided for stability. When installing gas monitors on flat surfaces, the plastic yellow feet are not required. Use size #6 (3mm) or #8 (4mm) screws for mounting.

Gas Type	Response Time (T90)
CO	T90 < 30 seconds
NO <sub>2</sub>	T90 < 30 seconds
CO <sub>2</sub> (0...2000 ppm)	T90 < 120 seconds
CO <sub>2</sub> (0...5000/10000 ppm)	T90 < 105 seconds
NH <sub>3</sub>	T90 < 75 seconds
CH <sub>4</sub>	T90 < 15 seconds
C <sub>3</sub> H <sub>8</sub>	T90 < 15 seconds
H <sub>2</sub>	T90 < 15 seconds
H <sub>2</sub> S	T90 < 30 seconds
CL <sub>2</sub>	T90 < 5 minutes
O <sub>2</sub> leak	T90 < 15 seconds
O <sub>2</sub> depletion (Ar, He, N <sub>2</sub> )	T90 < 15 seconds
Broadband Refrigerants	T90 < 60seconds

### 3.2 Wiring

**Power cable:** Use 18...20 AWG (2.5...0.5 mm<sup>2</sup>) single pair stranded copper cable for power.

\*When choosing the correct power cable size, please take voltage drop into account.

**Communication cable:** 22...24 AWG (0.34...0.25 mm<sup>2</sup>) twisted shielded pair, jacketed, 17 pF/ft or less, 100...120 ohm impedance, stranded cable.

#### 3.2.1 Wiring Diagram -A Model (22Gxx-5A/C-22G-5A)

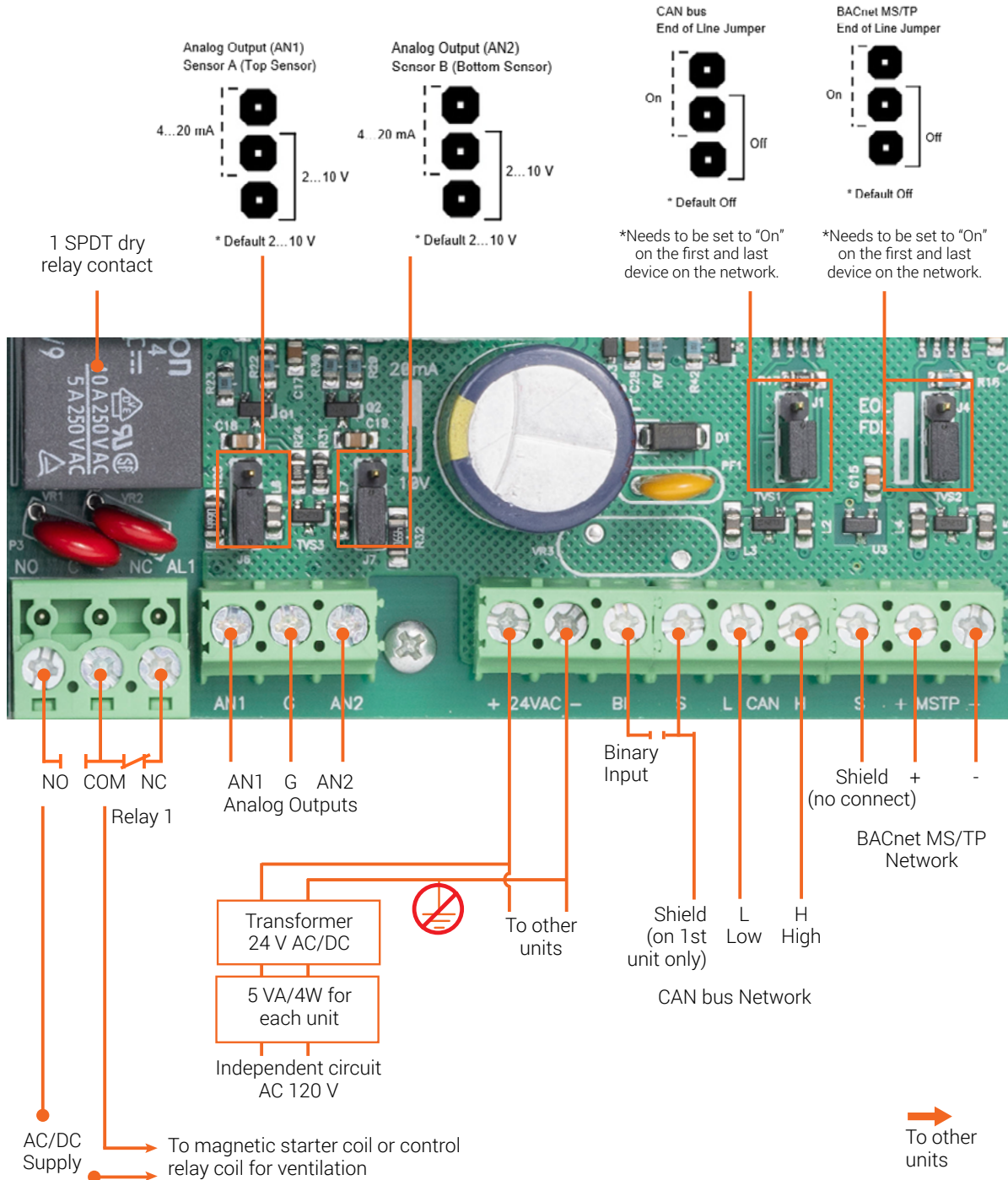

3.2.2 Wiring Diagram -B Model (22Gxx-5B/C-22G-5B)

2 SPDT dry contact relays

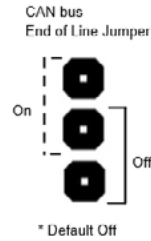

\*Needs to be set to "On" on the first and last device on the network.

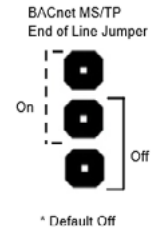

\*Needs to be set to "On" on the first and last device on the network.

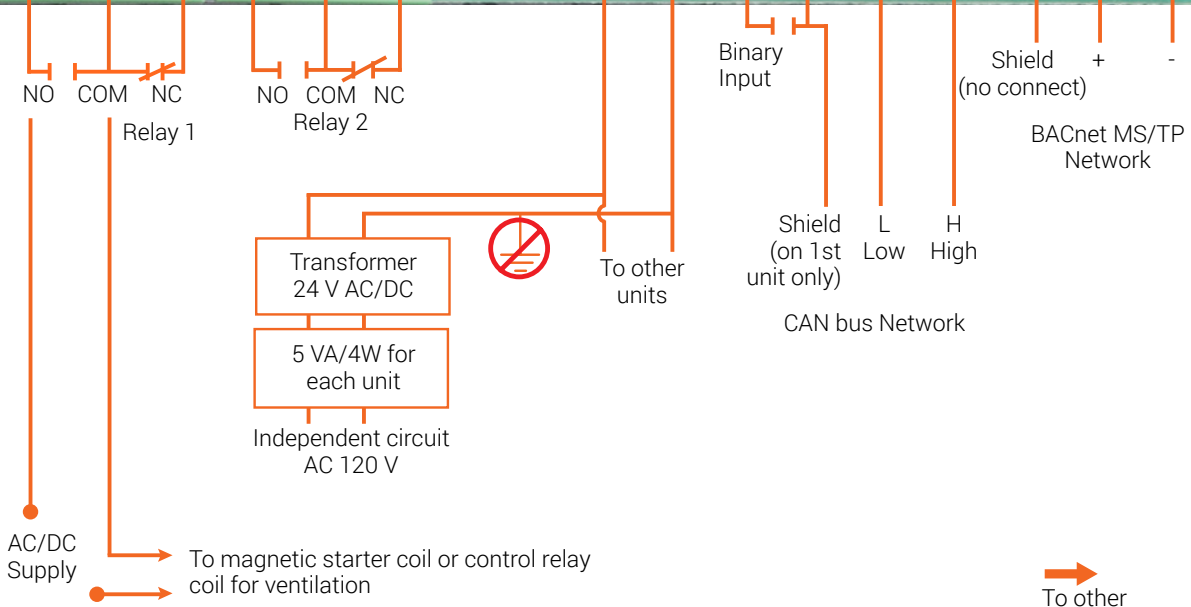
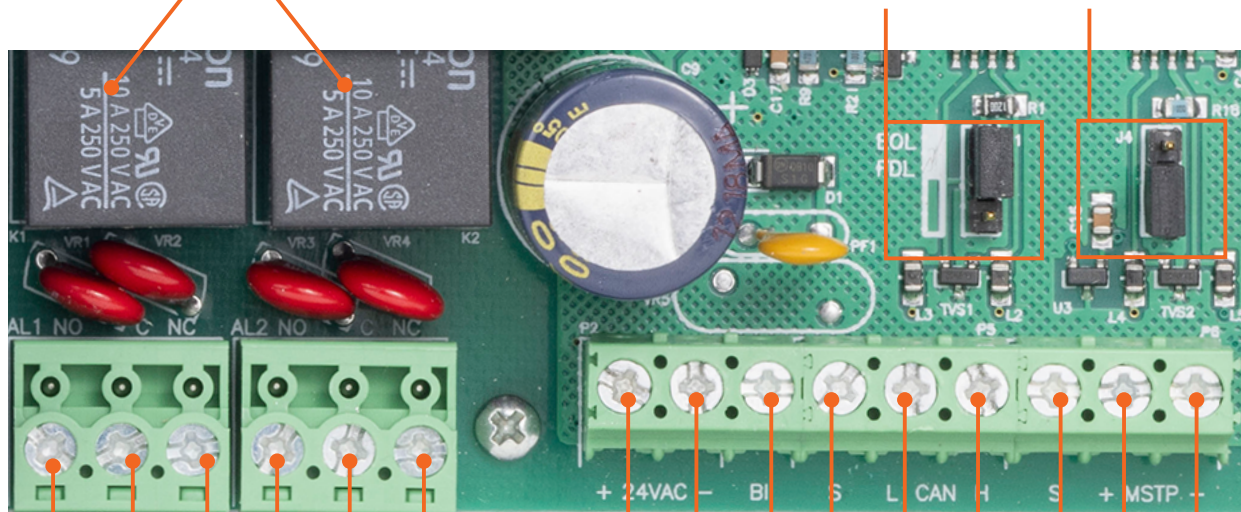

➔ To other units

### 3.2.3 Wiring Diagram -C Model (22Gxx-5C/C-22G-5C)

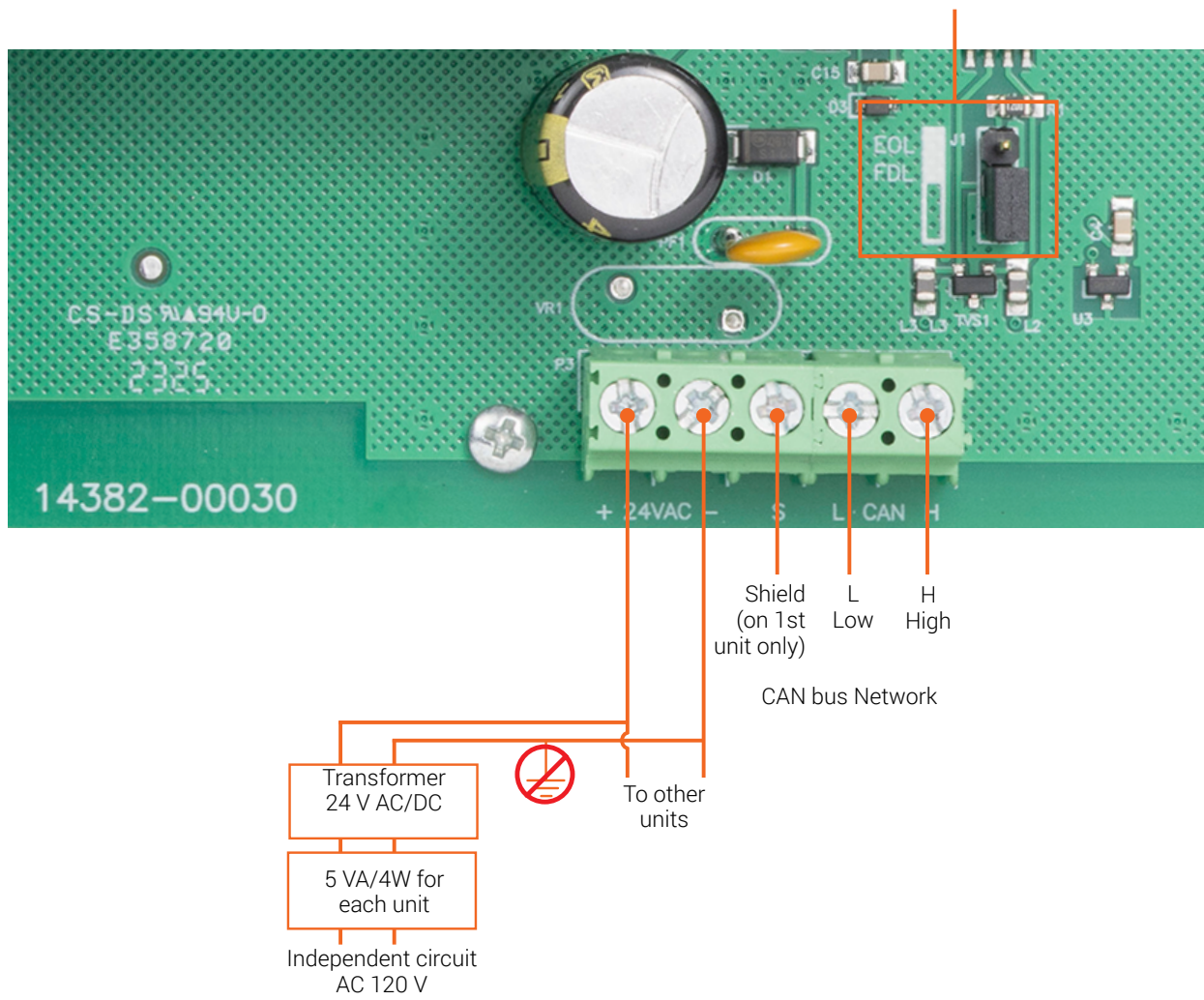
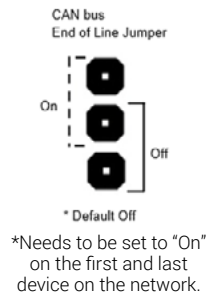

### 3.3 Start Up Check List

#### Important

All wiring must conform to local building codes, regulations and laws. If the equipment is used in a manner not specified by the manufacturer, the protection provided by the equipment may be impaired.

1. Use ½ inch EMT conduit for all wiring.
2. A switch or circuit breaker must be included in the installation. It must be suitably located and easily reached in a secure location and identified as the disconnect for the "Gas Monitoring System".
3. All Belimo gas monitors are powered by AC/DC 24 V. When using AC power, install an enclosed AC 120 to 24 V or AC 240 to 24 V transformer. When using DC power install a DC 24 V power supply. Consider 5 VA or 4.0 W for each device when sizing the transformer or power supply. Use 18...20 AWG (0.75...0.5 mm<sup>2</sup>) wire for power. \*Take voltage drop into account when choosing the correct power cable size. Connect multiple devices to one transformer, but do not tie the secondary of the transformer to the ground. Ensure the polarity of the positive and negative power wires are not shorted or crossed, otherwise communication and / or power will not function.
4. Connect the relay contacts (typically relay 1) to the ventilation system. Use a magnetic starter so that the gas monitor, communication module, or relay unit contacts energize the starter coil and not the fan motor directly. Relay contacts are rated at SPDT, 5A @ AC 125 V / 4A @ DC 24 V. When using the gas monitor relays to control external equipment that requires a greater load than 5 amps, an external relay with a higher current rating is required. Please consult Belimo for more information.
5. Use 22...24 AWG (0.34...0.25 mm<sup>2</sup>) twisted shielded pair, jacketed, 17 pF/ft or less, 100...120 ohm impedance, stranded cable for all communications (CAN bus and BACnet MS/TP). To wire CAN bus, connect the CAN Low wire on each device in the CAN "L" terminal, and the CAN High wire in the CAN "H" terminal. Daisy chain the CAN Low and CAN High wires to each remaining device. To wire BACnet MS/TP, connect the negative wire on each device in the MSTP "-" terminal and the positive wire in the MSTP "+" terminal. Daisy chain the "-" and "+" to each remaining device. Maintain the same polarity on each device. Do not use star, T, or H junctions, only a continuous daisy chain. Connect the shield for both CAN bus and BACnet MS/TP to the "S" terminals on the first device on the daisy chain only. Join the shields together at each additional device, but do not physically connect it to the "S" terminal of any other device.
6. When using CAN bus or BACnet MS/TP, it is essential to set end of line (EOL) jumpers on the first and last devices on the daisy chain network only. To do this, move the CAN bus and/or BACnet MS/TP end-of-line jumper to the ON position (by placing it on the top two pins) on only the first and last devices on the CAN bus and/or BACnet MS/TP network. Ensure all device's end-of-line jumpers are off (by placing the EOL jumper on the bottom two pins) if they are in the middle of the chain. \*All EOL jumpers are set to OFF by default when they leave Belimo. CAN bus and BACnet addresses can be in any location on the daisy chain.
7. Power on the devices. The screen will display BELIMO, the firmware version, and count down from 60 seconds. After the device warms up, the home screen will display the gas types, concentrations, and alarm level status. First, set a unique CAN bus address on each device on the CAN bus network. By default, all CAN bus addresses are set to 0. To do this, press and hold → until you reach menu setting 39 (Adr). Press ↑ to change the CAN bus address to any value between 0 and 31. (The daisy chain allows for up to 32 devices including values of 0 to 31. 0 is an address). Press ↑ and ← at the

same time to save. The screen will show "OK" if it was saved correctly, and the value will have changed. Press and hold ← to return to the home screen. Setting the CAN bus address does not need to be done on relay units.

8. Verify all devices are communicating on CAN bus by activating the network display, menu setting 56 (Net), on any one device. To do this, press and hold → until you reach menu setting 56. Press ↑ to change the value from 0 to 1 to turn on the network display. Press ↑ and ← at the same time to save. The screen will show "OK" if it was saved correctly. Press and hold ← to return to the home screen. Now the device will show all devices connected on CAN bus in order of their CAN address in a continuous repeating cycle. If any units do not show up on the network, go to the missing gas monitors and check the following:
  - each device must have a unique CAN bus address per programmable setting 39 (Adr), with no duplicates
  - end-of-line jumpers must be set to the ON position (by placing it on the top two pins) on the first and last devices on the CAN bus network only. (Do NOT set the end of line jumpers per floor or zone. Only set them where the entire daisy chain starts and ends).
  - polarity of both the communication cable and the power cable is the same and not crossed or shorted on all devices.
  - verify wire connections for shorts, loose wires, correct polarity.
  - verify voltage drop and that each device is getting the correct amount of power.
9. To test the system, from the home screen press and hold ↑ on any device for at least 5 seconds to manually trigger the alarm (by default it will activate alarm 1 for 5 minutes, but can be changed to deactivate between 5 to 60 minutes by pressing the ↑ and ↓ buttons). This will manually activate alarm level 1 and relay 1 on that device and all other devices on the same CAN bus network zone. Alarm level 2 and relay 2 or alarm level 3 can also be activated by changing menu setting 69 (Man) from M1, to M2 or M3, going back to the home screen, and then holding ↑ button for at least 5 seconds.

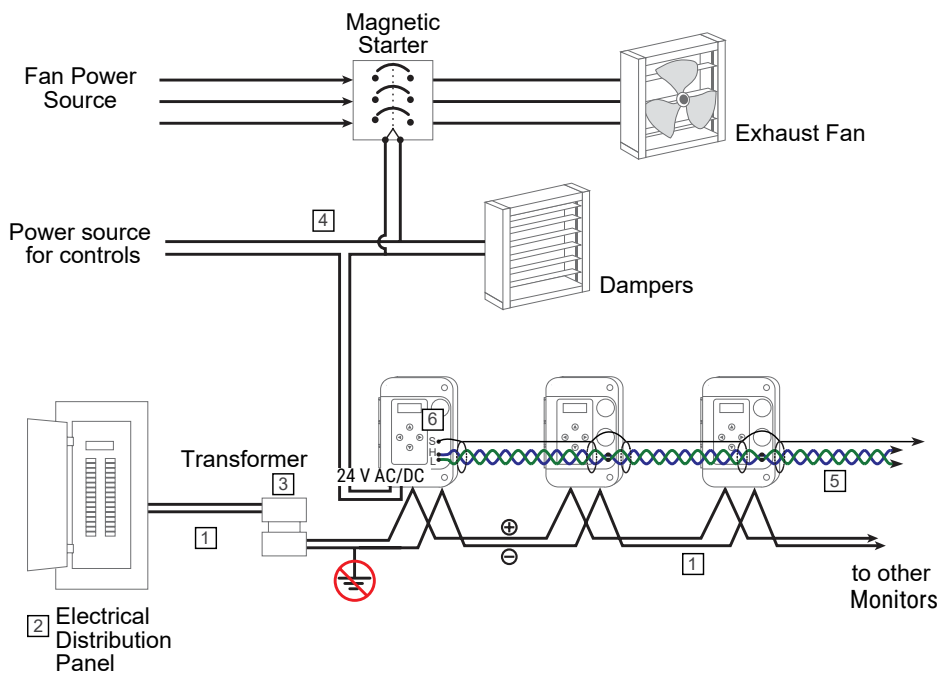

### 3.4 Warm-up Time

All Belimo gas monitors require a warm up time for the sensor modules to fully stabilize.

GAS TYPE IDENTIFICATION NUMBER	DESCRIPTION	WARM UP TIME
02 03 04 14 16 17	Carbon monoxide (CO) Carbon monoxide (CO) null H <sub>2</sub> Ammonia (NH <sub>3</sub> ) Nitrogen dioxide (NO <sub>2</sub> ) Hydrogen sulfide (H <sub>2</sub> S) Chlorine (Cl <sub>2</sub> )	5 minutes
15-003 15-005 15-006	Carbon dioxide (CO <sub>2</sub> ), 0...2000 ppm Carbon dioxide (CO <sub>2</sub> ), 0...5000 ppm Carbon dioxide (CO <sub>2</sub> ), 0...10000 ppm	10 minutes
21	Broadband refrigerant	1 hour
05 06 08	Methane/Natural gas (CH <sub>4</sub> ) Propane (C <sub>3</sub> H <sub>8</sub> ) Hydrogen (H <sub>2</sub> )	24 hours
22 23	Oxygen leak (O <sub>2</sub> ) Oxygen depletion (O <sub>2</sub> ) *Argon: Ar, Helium: He, Nitrogen: N <sub>2</sub>	48 hours

### 3.5 Broadband Refrigerant Monitor Zeroing Procedure and Refrigerant Selection

All Belimo gas monitors require a warm up time for the sensor modules to fully stabilize.

1. Wait 1 hour to allow the gas monitor to fully warm up and stabilize.
2. By default, the Belimo refrigerant gas monitor is programmed to monitor R134a. To monitor any other refrigerant gas from the list of selectable refrigerants, press and hold the → button until you reach menu setting 57 (Ref-A) and press the ↑ or ↓ buttons to find the targeted refrigerant. Once the targeted refrigerant is found, press the ← and ↑ buttons at the same time to save. If saved correctly, menu setting 57 (Ref-A) will show \*\*OK\*\* and the new refrigerant will be shown.
3. Once the gas monitor is installed in its final location and orientation, Press and hold → to reach menu setting 54 (ZeroC) and press ↑ and ↓ buttons at the same time. Wait 2 minutes, then verify that setting 54 (ZeroC) displays a value of "0±10", if not repeat this step.
4. Press and hold ← to return to the home screen. If set up correctly, the targeted refrigerant along with its concentration will be displayed on the screen.

\*List of User Selectable Refrigerants:

R11, R22, R23, R32, R125, R134a, R404A, R407A, R407C, R407F, R410A, R448A, R449A, R452A, R454B, R455A, R507, R513A, R1233zd, R1234yf, R1234ze

## 4.0 Operation

### 4.1 Home Screen Display

The home screen shows the gas types, concentrations, and alarm level status.

**Any value from 0 to 31** (top left corner) indicates the gas monitor CAN bus address. This setting is deactivated by default but can be activated via menu setting 56 (Net). This is the network display, and is a great CAN bus troubleshooting tool.

- 1** (bottom left corner) indicates that alarm level one has been activated. Alarm level one will always activate relay 1 (on all -A and -B models). The alarm level one set point is adjustable per menu settings 0 for sensor A (top sensor) and 18 for sensor B (bottom sensor). It can also be activated by other gas monitors on the CAN bus network per menu settings 36.
- 2** (bottom left corner) indicates that alarm level two has been activated. Alarm level two will always activate relay 2 (on all -B models). The alarm level two set point is adjustable per menu settings 3 for sensor A (top sensor) and 21 for sensor B (bottom sensor). It can also be activated by other gas monitors on the CAN bus network per menu settings 37.
- 3** (bottom left corner) indicates that alarm level three has been activated. Alarm level 3 will activate the horn and strobe alarm (unless they are deactivated per menu setting 45). The alarm level three set point is adjustable per menu settings 6 for sensor A (top sensor) and 24 for sensor B (bottom sensor). It can also be activated by other gas monitors on the CAN bus network per menu settings 38.
- M** (bottom left corner) indicates that manual override is on. It provides the ability to manually activate the alarms to make sure the system is operating properly. To manually trigger the alarm, from the home screen on any device, press and hold ↑ on for at least 5 seconds. This will manually activate alarm 1 and relay 1 on that device and all of the other devices on the same CAN bus network zone. Alarm 2 and relay 2 or alarm 3 can also be activated by changing menu setting 69 (Man) from M1, to M2 or M3, going back to the home screen, and then holding ↑ button for at least 5 seconds.
- T** indicates that alarm 1 has been activated due to the high temperature alarm. Each device has an internal temperature sensor to protect the space from overheating. By default, it is set to 60°C or 140°F, essentially off. To lower the set point, first select the units of measurement (°C/°F) per menu setting 72, and then select the set point per menu setting 51.

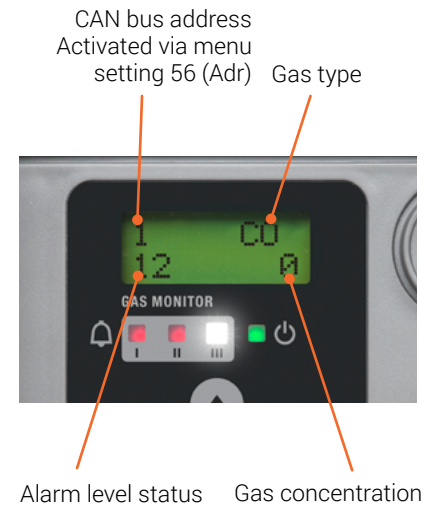

## 4.2 Default Alarm Set Points

Alarm setpoints are factory set with default values, but should be set to suit local regulations.

APPLICATION	GAS TYPE	GAS TYPE IDENTIFICATION NUMBER	MEASURING RANGE	ALARM 1 (DEFAULT)	ALARM 2 (DEFAULT)	ALARM 3 (DEFAULT)
<b>Vehicle Emissions</b>	Carbon monoxide (CO)	02	0...250 ppm	25 ppm	35 ppm	75 ppm
	Carbon monoxide (CO Null H <sub>2</sub> )	03	0...250 ppm	25 ppm	35 ppm	75 ppm
	Nitrogen dioxide (NO <sub>2</sub> )	14	0...10 ppm	0.5 ppm	1.0 ppm	2.0 ppm
<b>Indoor Air Quality</b>	Carbon dioxide (CO <sub>2</sub> )	15-xx3	0...2000 ppm	800 ppm	1200 ppm	1500 ppm
	Carbon dioxide (CO <sub>2</sub> )	15-xx5	0...5000 ppm	2000 ppm	3000 ppm	4000 ppm
	Carbon dioxide (CO <sub>2</sub> )	15-xx6	0...10000 ppm	2000 ppm	3000 ppm	4000 ppm
<b>Combustible and Toxic Gases</b>	Ammonia (NH <sub>3</sub> )	04	0...250 ppm	25 ppm	50 ppm	100 ppm
	Methane/ Natural Gas (CH <sub>4</sub> )	05	0...50% LEL	10% LEL	15% LEL	20% LEL
	Propane (C <sub>3</sub> H <sub>8</sub> )	06	0...50% LEL	10% LEL	15% LEL	20% LEL
	Hydrogen (H <sub>2</sub> )	08	0...50% LEL	10% LEL	15% LEL	20% LEL
	Hydrogen sulfide (H <sub>2</sub> S)	16	0...50 ppm	2.5 ppm	3.5 ppm	7.5 ppm
	Chlorine (CL <sub>2</sub> )	17	0...10 ppm	0.5 ppm	1.0 ppm	2.0 ppm
	Oxygen leak (O <sub>2</sub> Leak)	22	0...50% O <sub>2</sub>	24% O <sub>2</sub>	27% O <sub>2</sub>	30% O <sub>2</sub>
	Oxygen depletion (O <sub>2</sub> Dep.) *Argon: Ar *Helium: He *Nitrogen: N	23	0...50% O <sub>2</sub>	18% O <sub>2</sub>	17% O <sub>2</sub>	16% O <sub>2</sub>
<b>Refrigerant Gas Leak Detection</b>	Broadband Refrigerant (IR)	21	0...2000 ppm	250 ppm	350 ppm	750 ppm

per UL 2075 and ULC-S588 the alarm level set points for CO shall not exceed 200 ppm.

## 4.3 Button Basics

### Menu navigation

Scroll menu:	press ← or → button
Scroll fast:	press and hold → button
Exit menu:	press and hold ← button
Change menu settings:	press ↑ or ↓ button
Change menu settings fast:	press and hold ↑ or ↓ button
Save menu settings:	press ← and ↑ buttons at the same time
Default passcode:	↑ ↓ ↑ ↓ ↑ ↓
Manual override:	press and hold ↑ button for at least 5 seconds while at the home screen
Calibration menu:	press → button then press ↑ and → at the same time
View firmware:	press ← and ↓ buttons at the same time
Enter password:	*See specific section
Register sensor:	*See specific section

## 4.4 Reset Menu Settings

To reset all menu settings back to their factory default values, press and hold → until you reach menu setting 76 (RST P). Press ↑ button 3 times to change the value from A to ALL. To save, press ↑ and ← buttons at the same time. The word “\*RESET?\*” will appear on the screen. Press ↑ and ← buttons at the same time again. The gas monitor will then reboot with the factory default values.

This is a great troubleshooting tool, as Belimo gas monitors and communication modules have over 80 menu settings that can be changed and configured. If the settings are changed incorrectly, forgotten, or if the gas monitors are not functioning correctly, the settings can be reset and easily reprogrammed from scratch.

## 4.5 Password Protection

All gas monitors and communication modules can be password protected with a six-keystroke password. This locks the keypad and menu. The default password is ↑ ↓ ↑ ↓ ↑ ↓. To create a unique password, please follow the steps below.

### Activate Password Protection

1. Press → to enter menu.
2. Press and hold → until you reach setting MO PASS?  
\*This is the last setting, and it does not have a number.
3. Press ↑ to enter a new password.
4. Enter any six-keystroke password using the ↑ ↓ ← → buttons.
5. Re-enter the six keystroke password using the ↑ ↓ ← → buttons.
6. Hold ← to return to the home screen.
7. Press and hold → until you reach setting 49 (KBL).
8. Press ↑ to change the value from 0 to 1 to activate the keyboard lock.
9. Press ↑ and ← at the same time to save.
10. Hold ← to return to the home screen.

\*You should now be locked out. If the password was activated, you will hear two clicks every time a button is pressed.

### Deactivate Password Protection

1. Input your six-keystroke password to access the menu settings.  
\* If you enter your password and it does not work the first time, wait five seconds and try again slower.  
\* place the text that starts with the \* under the first line.
2. Press and hold → until you reach setting 49 (KBL).
3. Press ↓ to change the value from 1 to 0 to deactivate the keyboard lock.
4. Press ↑ and ← at the same time to save.
5. Hold ← to return to the home screen.

## 4.6 All Menu Settings

All menu settings are factory set with default values to facilitate set up and commissioning and can be changed at any time. Alarm setpoints are also factory set with default values but should be set to suit local regulations.

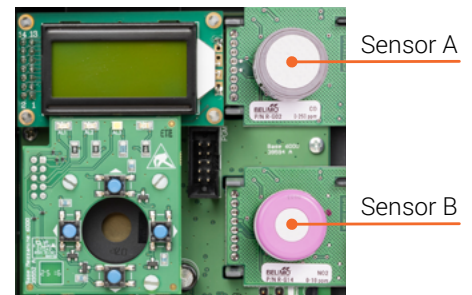

### Programmable settings for sensor A (top sensor)

NO.	NAME	DESCRIPTION	RANGE	DEFAULT
0	AL1	<b>Alarm 1 setpoint</b> <i>Gas concentration setpoint to activate alarm 1 and its corresponding relay 1 (on any -A or -B model).</i>	Gas specific. See section 4.2	Gas specific. See section 4.2
1	A1Del	<b>Alarm 1 delay on</b> <i>Time delay for how long the gas concentration must remain above the alarm 1 setpoint before alarm 1 is activated. Time delays prevent false alarms and short cycling of fans and other equipment.</i>	2...1000	30
2	A1Off	<b>Alarm 1 delay off</b> <i>Time delay for how long the gas concentration must drop below the alarm 1 setpoint before alarm 1 is deactivated.</i>	0...1000	20
3	AL2	<b>Alarm 2 setpoint</b> <i>Gas concentration setpoint to activate alarm 2 and its corresponding relay 2 (on any -B model).</i>	Gas specific. See section 4.2	Gas specific. See section 4.2
4	A2Del	<b>Alarm 2 delay on</b> <i>Time delay for how long the gas concentration must remain above the alarm 2 setpoint before alarm 2 is activated.</i>	2...1000	30
5	A2Off	<b>Alarm 2 delay off</b> <i>Time delay for how long the gas concentration must drop below the alarm 2 setpoint before alarm 2 is deactivated.</i>	0...1000	20
6	AL3	<b>Alarm 3 setpoint</b> <i>Gas concentration setpoint to activate alarm 3 and the internal horn and strobe alarm.</i>	Gas specific. See section 4.2	Gas specific. See section 4.2
7	A3Del	<b>Alarm 3 delay on</b> <i>Time delay for how long the gas concentration must remain above the alarm 3 setpoint before alarm 3 is activated.</i>	2...1000	180
8	A3Off	<b>Alarm 3 delay off</b> <i>Time delay for how long the gas concentration must drop below the alarm 3 setpoint before alarm 3 is deactivated.</i>	0...1000	20
9	A1Tx	<b>Alarm 1 transmit message, CAN bus</b> <i>Message sent via CAN bus to alert the other devices that alarm 1 has been activated.</i>	0...255	1
10	A1Tx	<b>Alarm 1 transmit message, CAN bus</b> <i>Optional second message sent via CAN bus to alert the other devices that alarm 1 has been activated.</i>	0...255	*0

\*0 = inactive

**Programmable settings for sensor A (top sensor)**

<b>NO.</b>	<b>NAME</b>	<b>DESCRIPTION</b>	<b>RANGE</b>	<b>DEFAULT</b>
<b>11</b>	A1Tx	<b>Alarm 1 transmit message, CAN bus</b> <i>Optional third message sent via CAN bus to alert the other devices that alarm 1 has been activated.</i>	0...255	*0
<b>12</b>	A2Tx	<b>Alarm 2 transmit message, CAN bus</b> <i>Message sent via CAN bus to alert the other devices that alarm 2 has been activated.</i>	0...255	2
<b>13</b>	A2Tx	<b>Alarm 2 transmit message, CAN bus</b> <i>Optional second message sent via CAN bus to alert the other devices that alarm 2 has been activated.</i>	0...255	*0
<b>14</b>	A2Tx	<b>Alarm 2 transmit message, CAN bus</b> <i>Optional third message sent via CAN bus to alert the other devices that alarm 2 has been activated.</i>	0...255	*0
<b>15</b>	A3Tx	<b>Alarm 3 transmit message, CAN bus</b> <i>Message sent via CAN bus to alert the other devices that alarm 3 has been activated.</i>	0...255	3
<b>16</b>	A3Tx	<b>Alarm 3 transmit message, CAN bus</b> <i>Optional second message sent via CAN bus to alert the other devices that alarm 3 has been activated.</i>	0...255	*0
<b>17</b>	A3Tx	<b>Alarm 3 transmit message, CAN bus</b> <i>Optional third message sent via CAN bus to alert the other devices that alarm 3 has been activated.</i>	0...255	*0

\*0 = inactive

**Programmable settings for sensor B (bottom sensor)**

NO.	NAME	DESCRIPTION	RANGE	DEFAULT
18	AL1-B	<b>Alarm 1 setpoint</b> <i>Gas concentration setpoint to activate alarm 1 and its corresponding relay 1 (on any -A or -B model).</i>	Gas specific. See section 4.2	Gas specific. See section 4.2
19	A1Del	<b>Alarm 1 delay on</b> <i>Time delay for how long the gas concentration must remain above the alarm 1 setpoint before alarm 1 is activated.</i>	2...1000	30
20	A1Off	<b>Alarm 1 delay off</b> <i>Time delay for how long the gas concentration must drop below the alarm 1 setpoint before alarm 1 is deactivated.</i>	0...1000	20
21	AL2-B	<b>Alarm 2 setpoint</b> <i>Gas concentration setpoint to activate alarm 2 and its corresponding relay 2 (on any -B model).</i>	Gas specific. See section 4.2	Gas specific. See section 4.2
22	A2Del	<b>Alarm 2 delay on</b> <i>Time delay for how long the gas concentration must remain above the alarm 2 setpoint before alarm 2 is activated.</i>	2...1000	30
23	A2Off	<b>Alarm 2 delay off</b> <i>Time delay for how long the gas concentration must drop below the alarm 2 setpoint before alarm 2 is deactivated.</i>	0...1000	20
24	AL3-B	<b>Alarm 3 setpoint</b> <i>Gas concentration setpoint to activate alarm 3 and the internal horn and strobe alarm.</i>	Gas specific. See section 4.2	Gas specific. See section 4.2
25	A3Del	<b>Alarm 3 delay on</b> <i>Time delay for how long the gas concentration must remain above the alarm 3 setpoint before alarm 3 is activated.</i>	2...1000	180
26	A3Off	<b>Alarm 3 delay off</b> <i>Time delay for how long the gas concentration must drop below the alarm 3 setpoint before alarm 3 is deactivated.</i>	0...1000	20
27	A1Tx	<b>Alarm 1 transmit message, CAN bus</b> <i>Message sent via CAN bus to alert the other devices on the CAN bus network that its alarm 1 has been activated.</i>	0...255	1
28	A1Tx	<b>Alarm 1 transmit message, CAN bus</b> <i>Optional second message sent via CAN bus to alert the other devices on the CAN bus network that its alarm 1 has been activated.</i>	0...255	*0
29	A1Tx	<b>Alarm 1 transmit message, CAN bus</b> <i>Optional third message sent via CAN bus to alert the other devices that alarm 1 has been activated.</i>	0...255	*0
30	A2Tx	<b>Alarm 2 transmit message, CAN bus</b> <i>Message sent via CAN bus to alert the other devices that alarm 2 has been activated.</i>	0...255	2

\*0 = inactive

**Programmable settings for sensor B (bottom sensor)**

NO.	NAME	DESCRIPTION	RANGE	DEFAULT
31	A2Tx	<b>Alarm 2 transmit message, CAN bus</b> <i>Optional second message sent via CAN bus to alert the other devices that alarm 2 has been activated.</i>	0...255	*0
32	BiTx	<b>Binary input transmit message, CAN bus</b> <i>Message sent via CAN bus to alert the other devices when the limit switch is closed, aka when the binary input and shield terminals are shorted. Used to manually activate ventilation via a push button.</i>	0...255	*0
33	A3Tx	<b>Alarm 3 transmit message, CAN bus</b> <i>Message sent via CAN bus to alert the other devices that alarm 3 has been activated.</i>	0...255	3
34	A3Tx	<b>Alarm 3 transmit message, CAN bus</b> <i>Optional second message sent via CAN bus to alert the other devices that alarm 3 has been activated.</i>	0...255	*0
35	A3Tx	<b>Alarm 3 transmit message, CAN bus</b> <i>Optional third message sent via CAN bus to alert the other devices that alarm 3 has been activated.</i>	0...255	*0

\*0 = inactive

## Programmable settings for all other sensors

NO.	NAME	DESCRIPTION	RANGE	DEFAULT
36	R1Rx	<b>Alarm 1 receive message, CAN bus</b> <i>Message received via CAN bus, to alert it that alarm 1 has been activated by another device on the network. Setting R1Rx to a value above 100 will disassociate the AL1 LED and relay 1 from sensors A and B, allowing a dedicated fault relay on the CAN bus network when used with menu setting 59 (FlTx).</i>	0...255	1
37	R2Rx	<b>Alarm 2 receive message, CAN bus</b> <i>Message received via CAN bus, to alert it that alarm 2 has been activated by another device on the network. Setting R2Rx to a value above 100 will disassociate the AL2 LED and relay 2 from sensors A and B, allowing a dedicated fault relay on the CAN bus network when used with menu setting 59 (FlTx).</i>	0...255	2
38	R3Rx	<b>Alarm 3 receive message, CAN bus</b> <i>Message received via CAN bus, to alert it that alarm 3 has been activated by another device on the network. Alarm 3 activates the internal horn and strobe alarm. By default, only the local horn and strobe alarm will activate, to not cause a mass panic.</i>	0...255	0
39	Adr	<b>Device address, CAN bus</b> <i>Each device on the CAN bus network must have a unique address. The available addresses are 0 to 31, 0 is a unique address.</i>	0...31	0
40	AnZA	<b>Analog output minimum point for sensor A (top sensor)</b> <i>Both analog outputs are min/max selectable. To configure the AN1 min. or max. value, use a multimeter and place the black lead on the "G" terminal and the red lead on the "AN1" terminal. Adjust to the desired analog output value shown on the multimeter, by adjusting the number on the gas monitor LCD using the ↑ and ↓ buttons. Press ↑ and ← at the same time on the gas monitor to save. To change the analog outputs to from VDC to mA, set the correct jumper on the PCB to the top two pins. Always remove the load source when configuring the analog outputs.</i>	0...1023	
41	AnSA	<b>Analog output maximum point for sensor A (top sensor)</b> <i>Both analog outputs are min/max selectable. To configure the AN1 min. or max. value, use a multimeter and place the black lead on the "G" terminal and the red lead on the "AN1" terminal. Adjust to the analog output value shown on the multimeter, by adjusting the number on the gas monitor LCD using the ↑ and ↓ buttons. Press ↑ and ← at the same time on the gas monitor to save. To change the analog outputs to from VDC to mA, set the correct jumper on the PCB to the top two pins. Always remove the load source when configuring the analog outputs.</i>	0...1023	
42	AnZB	<b>Analog output minimum point for sensor B (top sensor)</b> <i>Same process as 40 but place multimeter red lead on AN2.</i>	0...1023	
43	AnSB	<b>Analog output maximum point for sensor B (top sensor)</b> <i>Same process as 40 but place multimeter red lead on AN2.</i>	0...1023	
44	Temp	<b>Temperature display</b> 0 = Off 1 = On <i>Enables the internal temperature sensor to display the temperature reading on the home screen. The internal temperature sensor is not meant to replace a thermostat; it is meant to protect a space from overheating. It is recommended to be calibrated via menu setting 50 (TMod) after the device has been powered for at least 24 hours.</i>	0/1	*0

\*0 = inactive

## Programmable settings for all other sensors

NO.	NAME	DESCRIPTION	RANGE	DEFAULT
45	Aud	<p><b>Horn and strobe alarms</b></p> <p>0 = Internal horn and strobe disabled (-), missed calibration audible beep disabled (-).            1 = Internal horn and strobe enabled (+), missed calibration audible beep enabled (+).            2 = Internal horn and strobe enabled (+), missed calibration audible beep disabled (-).            3 = Internal horn and strobe disabled (-), missed calibration audible beep enabled (+).</p> <p><i>Enables or disables the internal horn and strobe alarm when alarm 3 is activated, and the missed calibration audible beep when the gas monitor is past due for recalibration. Both alarms are critical to provide a safe and functioning system.</i></p>	0/1/2/3	1
46	BAC	<p><b>Activation of BACnet MS/TP</b></p> <p>0 = BACnet MS/TP communication disabled (-)            1 = BACnet MS/TP communication enabled (+)            2 = BACnet MS/TP communication enabled (+), and all gas readings on CAN bus are brought into the BMS through BACnet MS/TP. <i>This allows any -A or -B model to be used as a CAN bus to BACnet MS/TP gateway, to tie the entire CAN bus system into a BMS through BACnet MS/TP.</i></p>	0/1/2	*0
47	BMA	<p><b>Device address, BACnet MS/TP</b></p> <p><i>All devices on the BACnet MS/TP network must have a unique address. The available addresses are 0 to 127, 0 is a unique address.</i></p>	0...127	1
48	BBR	<p><b>Baud rate, BACnet MS/TP (bits per second)</b></p> <p>0 = 9600            1 = 19200            2 = 38400            3 = 76800</p> <p><i>Power cycle the device when changing the BACnet MS/TP baud rate.</i></p>	0/1/2/3	3
49	KBL	<p><b>Keyboard lock</b></p> <p>0 = Off            1 = On</p> <p><i>Activates the default or user set password to lock the keypad and menu settings. The default password is ↑ ↓ ↑ ↓ ↑ ↓.</i></p>	0/1	*0
50	TMod	<p><b>Temperature sensor offset</b></p> <p><i>An offset to calibrate the internal temperature sensor. When using the internal temperature sensor, it is recommended to be calibrated after the device has been powered for at least 24 hours.</i></p>	±9°C ±9°F	-3°C -3°F
51	ATHi	<p><b>High temperature alarm setpoint</b></p> <p><i>A temperature setpoint used to activate alarm 1. This is used for summer ventilation to protect a space from overheating by activating alarm 1 when the ambient temperature exceeds this setpoint, to start ventilation and bring in cool outside air. Changing programmable setting 72 (temperature units, °C/°F) will return menu settings 51 and 55 back to their default values.</i></p>	0...90°C 0...150°F	60°C 140°F
52	W/U	<p><b>Warm-up delay (seconds)</b></p> <p><i>Allows communication to warm up and function properly. Alarms and relays are inactive during warm-up.</i></p>	0...255	60

\*0 = inactive

### Programmable settings for all other sensors

NO.	NAME	DESCRIPTION	RANGE	DEFAULT
53	BMM	<p><b>Maximum MAC address, BACnet MS/TP</b></p> <p>Used to increase the speed of BACnet MS/TP communication if there are many devices on the network. When changing this, set the BACnet MS/TP maximum MAC address no less than the highest BACnet MAC address on the network, otherwise devices will be hidden.</p>	0...127	127
54	BDiag/ ZeroC	<p><b>Troubleshooting tool, CAN bus / Broadband refrigerant monitor zeroing procedure</b></p> <p>In format XXXXYYZZ, where YY is MAC address (in hex) of the device that gives you the BACnet MS/TP token, and ZZ is the MAC address (in hex) of the device that receives the BACnet MS/TP token from you. Example 0305 would mean that your device receives the token from device #3 and passes it to device #5. For refrigerant gas leak detection monitors (22G21-5C), menu setting 54 is used to reset the zero point of the sensor module. This needs to be done after installation.</p>		
55	ATLo	<p><b>Low temperature alarm setpoint</b></p> <p>0 = Off</p> <p>A temperature setpoint used to activate alarm 3 (and the internal horn and strobe alarm). This is used to protect equipment from freezing by alerting someone or the BMS to close the outside air dampers or shut off the fan. Alarm 3 is activated when the temperature drops below this set point. When using this feature, NEVER set the low temperature alarm setpoint lower than 40°F [4°C], do NOT set it at 32°F [0°C]. Changing menu setting 72 (temperature units, °C/°F) will return menu settings 51 and 55 back to their default values.</p>	0...90°C 0...90°F	*0
56	Net	<p><b>Network display / troubleshooting tool, CAN bus</b></p> <p>0 = Off 1 = On</p> <p>The CAN bus network display enables the home screen on any device to remotely view all devices on the CAN bus network. This also allows easy troubleshooting of the CAN bus network upon start up and annual maintenance, to see if all devices are communicating properly, and pinpoint any devices which are not communicating.</p>	0/1	*0
57	Ref-A	<p><b>Broadband Refrigerant Monitor Refrigerant Selection</b></p> <p>Used for the 22G21-5C broadband refrigerant monitor only. This allows the user to select the specific refrigerant type and scale. Available refrigerants to select from include R11, R22, R23, R32, R125, R134a, R404A, R407A, R407C, R407F, R410A, R448A, R449A, R452A, R454B, R455A, R507, R513A, R1233zd, R1234yf, R1234ze.</p>	selectable from list	R134a
58	Ref-B			
59	FltTx	<p><b>Fault alarm transmit message, CAN bus</b></p> <p>Message sent via CAN bus to alert the other devices that there is a fault. If a fault is present, the home screen of the affected product will flash, beep, and display a fault code to pinpoint the issue. Faults can occur from too low or high voltage, sensors A or B being removed or installed incorrectly, if sensors A or B need to be recalibrated or replaced, or if any device loses power or drops off of the CAN bus network. Setting FltTx and R1Rx or R2Rx to a value above 100 will disassociate its AL LED and corresponding relay from sensors A and B, allowing for a dedicated fault relay on the CAN bus network.</p>	0...255	*0

\*0 = inactive

## Programmable settings for all other sensors

NO.	NAME	DESCRIPTION	RANGE	DEFAULT
60	ADTxA	<p><b>Analog output transmit channel for sensor A (top sensor), CAN bus</b> 0 = Off</p> <p>Separate CAN bus channels that allow AN1 to be controlled via the local gas reading from sensor A (top sensor), sensor B (bottom sensor), both sensors A and B (top and bottom), or via the gas readings from any/all devices on the CAN bus network. When controlled via any/all devices on the CAN bus network, by default, AN1 will be controlled based on the highest reading wins.</p> <p>To control AN1 via the gas readings from any or all devices on CAN bus, program menu setting 63 (ADRxA) (on the device with the analog outputs), and menu settings 60 (ADTxA) and 64 (ADTxB) (on all devices) to the same value.</p> <p>Program only menu setting 60 (ADTxA) if AN1 should be controlled via the top sensors (sensor A's only).</p> <p>Program only menu setting 64 (ADTxB) if AN1 should be controlled via the bottom sensors (sensor B's only).</p> <p>Program both menu settings 60 and 64 (ADTxA and ADTxB) if AN1 should be controlled via both the top and bottom sensors (sensor A's and B's).</p>	0...255	*0
61	AMinA	<p><b>Analog output minimum percent of scale for sensor A (top sensor)</b></p> <p>Allows the ability to program AN1 to stay at the min. point until a specified concentration of gas is reached. The minimum and maximum percentage of scales are set based on the desired set point in relation to the full range of the sensor. Please see the example below.</p> <p>Example scenario: Stay at 2V until 25 ppm CO or 0.5 ppm NO<sub>2</sub> is reached. Jump to 10V when 75 ppm CO or 2 ppm NO<sub>2</sub> is reached. Value = (Setpoint / Full range of sensor) x 100. CO: (25 ppm / 250 ppm) x 100 = 10%, (75 ppm / 250 ppm) x 100 = 30%. NO<sub>2</sub>: (0.5 ppm) x 100 = 5%, (2.0 ppm / 10 ppm) x 100 = 20%. Assumption CO sensor is in slot A (top sensor) and NO<sub>2</sub> sensor is in slot B (bottom sensor). CO: Set menu settings 61 (AMinA) to 10 and 62 (AMinA) to 30. NO<sub>2</sub>: Set menu settings 65 (AMinB) to 5 and 66 (AMaxB) to 20.</p>	0...100	0
62	AMaxA	<p><b>Analog output maximum percent of scale, sensor A (top sensor)</b></p> <p>Allows the ability to program AN1 to jump to the analog output max. point after a specified concentration of gas is reached. See example on menu setting 61.</p>	0...100	100
63	ADRxA	<p><b>Analog output receive channel for sensor A (top sensor), CAN bus</b> 0 = Off</p> <p>Allows the ability to control AN1 via the gas readings from any or all devices on the CAN bus network. See example on menu setting 60.</p>	0...255	*0

\*0 = inactive

## Programmable settings for all other sensors

NO.	NAME	DESCRIPTION	RANGE	DEFAULT
64	ADTxB	<p><b>Analog output transmit channel for sensor B (bottom sensor), CAN bus</b> 0 = Off</p> <p>Separate CAN bus channels that allow AN2 to be controlled via the local gas reading from sensor A (top sensor), sensor B (bottom sensor), both sensors A and B (top and bottom), or via the gas readings from any/all devices on the CAN bus network. When controlled via any/all devices on the CAN bus network, by default, AN2 will be controlled based on the highest reading wins.</p> <p>To control AN2 via the gas readings from any or all devices on CAN bus, program menu setting 63 (ADRxA) (on the device with the analog outputs), and menu settings 60 (ADTxA) and 64 (ADTxB) (on all devices) to the same value.</p> <p>Program only menu setting 60 (ADTxA) if AN2 should be controlled via the top sensors (sensor A's only).</p> <p>Program only menu setting 64 (ADTxB) if AN2 should be controlled via the bottom sensors (sensor B's only).</p> <p>Program both menu settings 60 and 64 (ADTxA and ADTxB) if AN2 should be controlled via both the top and bottom sensors (sensor A's and B's).</p>	0...255	*0
65	AMinB	<p><b>Analog output minimum percent of scale for sensor B (bottom sensor)</b></p> <p>Allows the ability to program AN2 to stay at the min. point until a specified concentration of gas is reached. The minimum and maximum percentage of scales are set based on the desired set point in relation to the full range of the sensor. See example on menu setting 61.</p>	0...255	0
66	AMaxB	<p><b>Analog drive maximum percent of scale for sensor B (bottom sensor)</b></p> <p>Allows the ability to program AN2 to jump to the analog output max. point after a specified concentration of gas is reached. See example on menu setting 61.</p>	0...100	100
67	ADRxB	<p><b>Analog output receive channel for sensor B (bottom sensor), CAN bus</b> 0 = Off</p> <p>Allows the ability to control AN2 via the gas readings from any or all devices on the CAN bus network. See example on menu setting 60.</p>	0...255	*0
68	Baud	<p><b>Baud rate, CAN bus</b> 0 = CAN bus high speed 1 = CAN bus low speed</p> <p>Use CAN bus high speed if the total CAN bus wire length is 1500 feet or less. Use CAN bus low speed if the total CAN bus wire length is between 1500 feet to 3000 feet. The device will automatically reboot after the CAN bus baud rate is changed. Power cycle the device if it does not automatically reboot.</p>	0/1	0
69	Man	<p><b>Manual override</b> M1 = manually activates alarm 1 M2 = manually activates alarm 1 and 2 M3 = manually activates alarm 1, 2, and 3</p> <p>Used to manually activate alarm 1, alarm 2, or alarm 3 to test the system for functionality. To activate manual override, return to the home screen and press ↑ for at least 5 seconds. To deactivate the manual override, press the ↓ button until it shuts off.</p>	M1/M2/ M3	1
70	BDI	<p>Device instance, BACnet MS/TP Enter part 1 (1000 to 4,194,303) Press right arrow Enter part 2 (0 to 999)</p>	0...4,194, 303	60,000 +BMA

\*0 = inactive

## Programmable settings for all other sensors

NO.	NAME	DESCRIPTION	RANGE	DEFAULT
71	Light	0 = backlight on when keyboard is activated 1 = backlight always on	0/1	0
72	°C/°F	<b>Manual override</b> 0 = °C 1 = °F <i>Changes the units of the internal temperature sensor to degrees Celsius or Fahrenheit. Changing menu setting 72 will revert menu settings 51 and 55 back to their default values.</i>	0/1	0
73	Cycle	<b>Automatic cycle timer (minutes)</b> 00C = total cycle time (minutes) 00R = total run time (minutes) <i>Allows for scheduled ventilation in addition to ventilation on demand via gas concentrations. Press → button to change 00R.</i>  <i>Example: Initiate scheduled ventilation every hour for 15 minutes.</i> 45C = total cycle time (minutes) 15R = run time (minutes)	0...255	*00/00 (inactive)
74	Age A/B	<b>Sensor module age (days)</b> <i>Age of sensor A (top sensor) in days.</i> <i>Age of sensor B (bottom sensor) in days.</i> <i>Press → button to view the age of sensor B (bottom sensor). The sensor module age will increase by one every 24 hours the gas monitor is powered.</i>		
75	VSD A	<b>Variable speed drive logic, CAN bus</b> 0 = highest reading wins 1 = average of the sensor readings 2 = auto ramping that increases or decreases by one-minute intervals <i>Used in combination with settings 60 through 67 to combine and control the analog outputs to control a VFD.</i>	0/1/2	0
76	RST P	<b>Reset parameters</b> A = Resets all alarm set points for sensor A (top sensor) B = Resets all alarm set points for sensor B (bottom sensor) A+B = Resets all alarm set points for sensor A (top sensor) and sensor B (bottom sensor) ALL = Resets all menu settings back to Belimo default values. <i>Resetting the alarm set points (A, B, or A+B) only resets settings 0, 3, 6 for sensor A (top sensor), and/or settings 18, 21, 24 for sensor B (bottom sensor). Resetting all settings back to their Belimo default values (ALL) is a great troubleshooting tool to fix any non or mis functioning systems by starting over and programming the system from scratch.</i>	A/B/A+B/ All	0
77	NQty	<b>Number of devices on CAN bus network</b> 0 = Deactivated <i>Allows the user to select the number of devices (including gas monitors and communication modules) on the CAN bus network, so that if any drop offline or loose power from damage or failure of the device, the system will detect a fault on the network. When using this setting, this should be set last, after the end of line (EOL) jumpers are set, CAN bus addresses are set, and after checking that all devices are communicating properly on the CAN bus network per menu setting 56. Used with menu setting 59 (FltTx) to activate a relay from a fault.</i>	0...32	*0

\*0 = inactive

### Programmable settings for all other sensors

NO.	NAME	DESCRIPTION	RANGE	DEFAULT
78	BAC A	<p><b>Activating CAN bus alarms and relays at the BMS through BACnet MS/TP</b></p> <p>0 = Deactivated</p> <p>1 = CAN bus transmit messages from the BACnet to CAN bus gateway device for alarm 1 is activated via BACnet MS/TP.</p> <p>2 = CAN bus transmit messages from the BACnet to CAN bus gateway device for alarm 2 is activated via BACnet MS/TP.</p> <p>3 = CAN bus transmit messages from the BACnet to CAN bus gateway device for alarm 3 is activated via BACnet MS/TP.</p> <p>4 = CAN bus transmit messages from the BACnet to CAN bus gateway device for alarms 1, 2, and 3 activated via BACnet MS/TP.</p> <p><i>Allows the ability to activate all CAN bus alarms and relays at the BMS through BACnet MS/TP by sending the CAN bus transmit messages when alarm 1, alarm 2, alarm 3, or all alarms are activated on the -A or -B model used as the BACnet MS/TP to CAN bus gateway device.</i></p>	0/1/2/3/4	*0
79	LATCH	<p><b>Manual reset/latched alarms and relays</b></p> <p>0 = Deactivated. Alarms and relays deactivate automatically.</p> <p>1 = Alarm 1 remains active until it is manually reset.</p> <p>2 = Alarm 2 remains active until it is manually reset.</p> <p>3 = Alarm 3 remains active until it is manually reset.</p> <p>4 = Alarms 1, 2, and 3 will remain active until they are manually reset.</p> <p><i>Latches the alarm and its corresponding relay, causing it to stay activated even after gas levels have returned to safe levels. Manual reset / latched alarms are used to notify personnel when an issue occurs, so that once gas levels are safe, someone is required to go, check, and fix the issue, so that it does not reoccur. To unlatch the alarms, someone must physically go to the product and press the ↓ button. The display will read "AL OFF".</i></p>	0/1/2/3/4	*0
80	SERVA	<p><b>Calibration overdue warning for sensor A (top sensor)</b></p> <p><i>Gas monitors are required to be calibrated every year. By default, all Belimo gas monitors have a calibration overdue warning set to 390 days. After 390 days, if the gas monitor has not been recalibrated, the screen will flash and beep and display "SERV.AB OVERDUE". The beep can be silenced per menu setting 45 (Aud). The calibration timer is reset whenever the gas monitor is recalibrated or replaced.</i></p>	0...3560	390
81	SERVB	<p><b>Calibration overdue warning for sensor B (bottom sensor)</b></p> <p><i>Same as the previous setting 80.</i></p>	0...3650	390
	MO PASS?	<p><b>Password protection</b></p> <p><i>Allows the user to select a six-keystroke password to lock the keypad and menu settings.</i></p>		

\*0 = inactive

## 4.7 Sequence of Operations

1. Gas monitors and communication modules are preloaded with default menu settings for normal operation and can be changed at any time via the keypad.
2. When the device powers on, the screen will display the firmware version number, and the warm-up timer will count down from 60 seconds. Alarms and relays are inactive during warm-up. Please note that in addition to the gas monitor warm-up time, all sensor modules have a warm-up time to fully stabilize and sense properly.
3. After warm-up, the screen will display the gas type, gas concentration, and alarm level status of both gases.
4. If gas levels rise above the alarm 1 set point, then the delay on timer for alarm 1 will start (default 30 seconds). The timer will clear and reset whenever gas levels drop below the alarm 1 set point.
5. If gas levels stay above the alarm 1 set point longer than the delay on timer (default 30 seconds), alarm 1 will activate, causing the red LED for alarm 1 to turn on, relay 1 will energize, and the alarm 1 transmit message will be sent through CAN bus to alert the other devices that alarm 1 has been activated.
6. If gas levels drop below the alarm 1 set point, then the delay off timer will start (default 20 seconds). The timer will clear and reset whenever gas levels rise above the alarm 1 set point again.
7. If gas levels stay below the alarm 1 set point longer than the delay off timer (default 20 seconds), alarm 1 will deactivate, causing the red LED for alarm 1 to turn off, relay 1 will deenergize, and the alarm 1 transmit message will stop being sent through CAN bus.
8. If gas levels rise above the alarm 2 set point, then the delay on timer for alarm 2 will start (default 30 seconds). The timer will clear and reset whenever gas levels drop below the alarm 2 set point.
9. If gas levels stay above the alarm 2 set point longer than the delay on timer (default 30 seconds), alarms 1 and 2 will activate, causing the red LEDs for both alarm 1 and 2 to turn on, relay 1 and 2 will energize, and both alarm 1 and alarm 2 transmit messages will be sent through CAN bus to alert the other devices that alarm 1 and alarm 2 have been activated.
10. If gas levels drop below the alarm 2 set point, then the delay off timer will start (default 20 seconds). The timer will clear and reset whenever gas levels rise above the alarm 2 set point again.
11. If gas levels stay below the alarm 2 set point longer than the delay off timer (default 20 seconds), alarm 2 will deactivate, causing the red LED for alarm 2 to turn off, relay 2 will deenergize, and the alarm 2 transmit message will stop being sent through CAN bus.
12. If gas levels rise above the alarm 3 set point, then the delay on timer for alarm 3 will start (default 180 seconds). The timer will clear and reset whenever gas levels drop below the alarm 3 set point.
13. If gas levels stay above the alarm 3 set point longer than the delay on timer (default 180 seconds), alarm 3 will activate, causing the flashing white LED and internal horn alarm to activate, , and the alarm 3 transmit message will be sent through CAN bus to alert the other devices that alarm 3 has been activated.

14. If gas levels drop below the alarm 3 set point, then the delay off timer will start (default 20 seconds). The timer will clear and reset whenever gas levels rise above the alarm 3 set point again.
15. If gas levels stay below the alarm 3 set point longer than the delay off timer (default 20 seconds), alarm 3 will deactivate, causing the flashing white LED and internal horn alarm to turn off, and alarm 3 transmit message will stop being sent through CAN bus.
16. If the network display is turned on (menu setting 56, by default it is turned OFF on all gas monitors and turned ON on all communication modules), the home screen will display each device that is connected via CAN bus, its address, gas type, gas concentration, and alarm level status. Each device will display for 3 seconds and then cycle to the next, in order of lowest CAN bus address to the highest and then start again.
17. If a gas monitor experiences any faults, a code can be sent through CAN bus to alert the other devices that a fault is present, (menu setting 59, disabled by default), to other gas monitors and communication modules on the CAN bus network.
18. Manual override mode is available to test relay and alarm functions by manually activating all three alarms. From the home screen press and hold ↑ button for at least 5 seconds to manually activate the alarm. Press the ↑ button to increase the timer by 5 minutes per click up to 60 minutes. The screen will display MAN 5 and timer will energize relay 1 and send the alarm 1 transmit message on the CAN bus network. After the time runs down the unit will return to automatic operation. To cancel, press ↓ button several times to reduce the timer to zero and return to normal operation. To activate alarm level 2 or 3 as well with this procedure, set menu setting 69 to M2 or M3.

# 5.0 Network configuration (CAN bus)

## 5.1 Zoned Ventilation

Belimo gas monitors have 3 adjustable alarm set points. When any gas monitor activates an alarm, it will transmit the alarm through CAN bus to alert the other devices. CAN bus transmit and receive messages are how the gas monitors can be programmed to zone ventilation on the same CAN bus network.

## 5.2 Transmit and Receive Messages

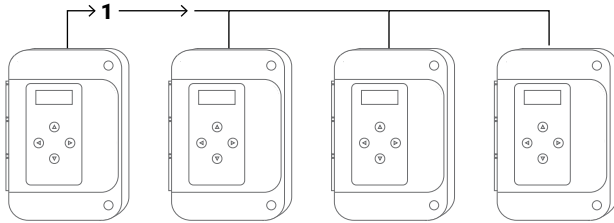

Using the default settings, if alarm 1 is activated, a "1" will be sent on CAN bus, if alarm 2 is activated, a "2" will be sent on CAN bus, and if alarm 3 is activated, a "3" will be sent on CAN bus. These numbers are what we call transmit messages. You can transmit up to 3 different messages for each alarm level.

The transmit messages below apply to sensor A (top sensor) only.

MENU SETTING	DEFAULT VALUE	DESCRIPTION
<b>9</b>	1	Alarm 1 transmit message Sensor A
<b>10</b>	0	Alarm 1 transmit message Sensor A
<b>11</b>	0	Alarm 1 transmit message Sensor A
<b>12</b>	2	Alarm 2 transmit message Sensor A
<b>13</b>	0	Alarm 2 transmit message Sensor A
<b>14</b>	0	Alarm 2 transmit message Sensor A
<b>15</b>	3	Alarm 3 transmit message Sensor A
<b>16</b>	0	Alarm 3 transmit message Sensor A
<b>17</b>	0	Alarm 3 transmit message Sensor A

0=Deactivated

The transmit messages below apply to sensor B (bottom sensor) only.

MENU SETTING	DEFAULT VALUE	DESCRIPTION
<b>27</b>	1	Alarm 1 transmit message Sensor B
<b>28</b>	0	Alarm 1 transmit message Sensor B
<b>29</b>	0	Alarm 1 transmit message Sensor B
<b>30</b>	2	Alarm 2 transmit message Sensor B
<b>31</b>	0	Alarm 2 transmit message Sensor B
<b>32</b>	0	See binary input section
<b>33</b>	3	Alarm 3 transmit message Sensor B
<b>34</b>	0	Alarm 3 transmit message Sensor B
<b>35</b>	0	Alarm 3 transmit message Sensor B

0=Deactivated

Receive messages determine what the other gas monitors will do in response to a transmitted message. If multiple gas monitors have the same transmit and receive messages, they will go into alarm together and operate as one zone. To program the gas monitors to zone ventilation on the same CAN bus network, set unique transmit and receive messages specific to each zone.

The receive messages below are used for relay and LED activation.

MENU SETTING	DEFAULT VALUE	DESCRIPTION
<b>36</b>	1	Alarm 1 receive message to activate alarm 1 and relay 1 (if any)
<b>37</b>	2	Alarm 2 receive message to activate alarm 2 and relay 2 (if any)
<b>38</b>	0	Alarm 3 receive message to activate alarm 3 and internal horn and strobe

0=Deactivated

For this example, if one gas monitor activates its alarm 1, it will send a transmit message of "1" through CAN bus.

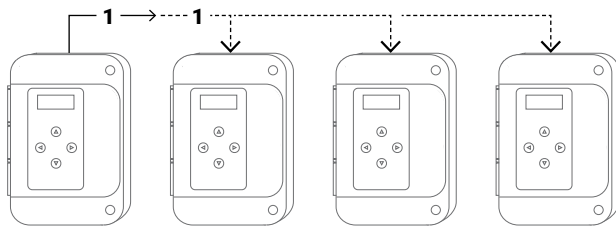

For this next example, if one gas monitor activates all three alarm levels (1, 2, 3), then it will send all three transmit messages "1", "2", "3" through CAN bus.

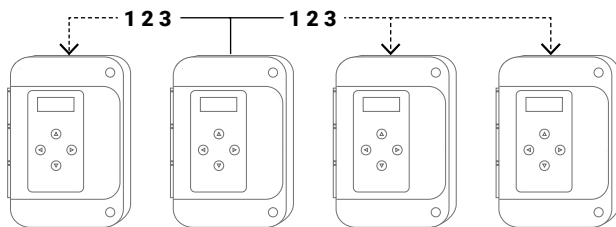

Note that by default, the other gas monitors will receive messages "1" and "2" but will ignore "3" because the receive message is set to "0". Alarm 3 activates the internal horn and strobe alarm. Ignoring alarm 3 is intentional, so that only the local horn and strobe activates, not the entire network. If it was changed to "3" on all gas monitors, all of them would activate their internal horn and strobe together.

MENU SETTING	DEFAULT VALUE	DESCRIPTION
36	1	Alarm 1 receive message to activate alarm 1 and relay 1 (if any)
37	2	Alarm 2 receive message to activate alarm 2 and relay 2 (if any)
38	0	Alarm 3 receive message to activate alarm 3 and internal horn and strobe

0=Deactivated

### 5.3 Practical Application

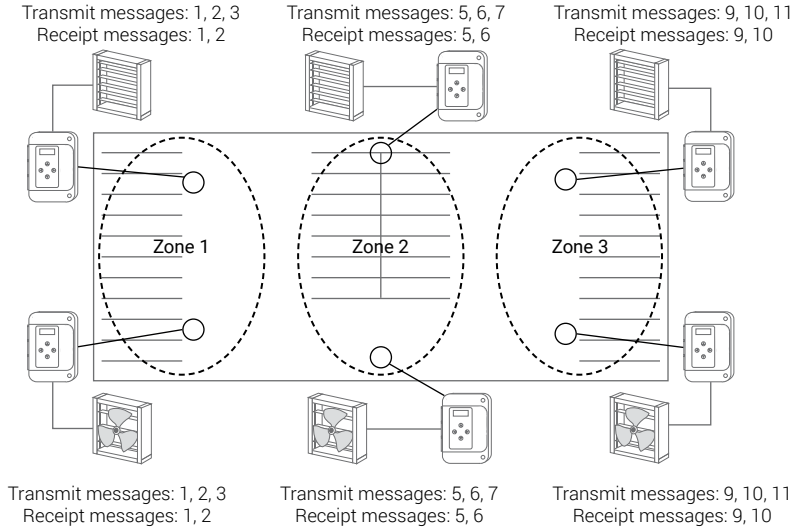

In this example, we have 3 zones in a parking garage, and each zone has its own fresh air intake damper and exhaust fan. All 6 monitors are on the same CAN bus network. If you simply used the default settings that are preprogrammed on all gas monitors, if one monitor goes into alarm, then they would all go into alarm because the transmit and receive codes are all the same.

If we change the transmit and receive messages, we can zone the system so that only select monitors go into alarm together. That way, if a gas monitor in zone 3 goes into alarm, only the fan and damper in zone 3 activates. Because we have changed the transmit and receive messages for zones 2 and 3, each zone will ignore the transmit messages being sent by the other zones.

For this example, if a gas monitor in zone 1 activates its alarm 1, it will send a transmit message of "1" through CAN bus. Since we changed the transmit and receive messages for zone 2, and zone 3, (to not receive a "1"), the gas monitors in zones 2 and 3 will ignore the "1" and not go into alarm.

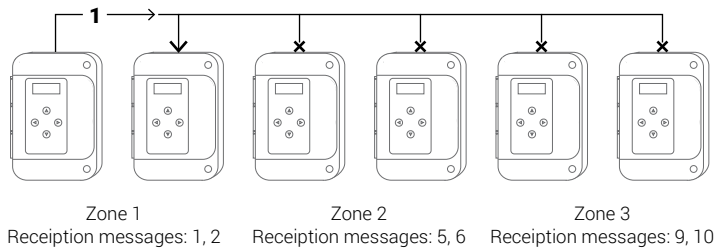

These are the messages you need to program into all 6 gas monitors, according to each zone.

**Zone 1**

MENU SETTING	DEFAULT VALUE	DESCRIPTION
9	1	alarm 1 transmit message
10	0	alarm 1 transmit message
11	0	alarm 1 transmit message
12	2	alarm 2 transmit message
13	0	alarm 2 transmit message
14	0	alarm 2 transmit message
15	3	alarm 3 transmit message
16	0	alarm 3 transmit message
17	0	alarm 3 transmit message
36	1	alarm 1 transmit message
37	2	alarm 2 transmit message
38	0	alarm 3 transmit message

**Zone 2**

MENU SETTING	DEFAULT VALUE	DESCRIPTION
9	5	alarm 1 transmit message
10	0	alarm 1 transmit message
11	0	alarm 1 transmit message
12	6	alarm 2 transmit message
13	0	alarm 2 transmit message
14	0	alarm 2 transmit message
15	7	alarm 3 transmit message
16	0	alarm 3 transmit message
17	0	alarm 3 transmit message
36	5	alarm 1 transmit message
37	6	alarm 2 transmit message
38	0	alarm 3 transmit message

**Zone 3**

<b>MENU SETTING</b>	<b>DEFAULT VALUE</b>	<b>DESCRIPTION</b>
<b>9</b>	9	alarm 1 transmit message
<b>10</b>	0	alarm 1 transmit message
<b>11</b>	0	alarm 1 transmit message
<b>12</b>	10	alarm 2 transmit message
<b>13</b>	0	alarm 2 transmit message
<b>14</b>	0	alarm 2 transmit message
<b>15</b>	11	alarm 3 transmit message
<b>16</b>	0	alarm 3 transmit message
<b>17</b>	0	alarm 3 transmit message
<b>36</b>	9	alarm 1 transmit message
<b>37</b>	10	alarm 2 transmit message
<b>38</b>	0	alarm 3 transmit message

- Note that messages being sent over CAN bus do not apply to the sender. For example, if a gas monitor has transmit messages 1 and 2 for alarm 1, that monitor will only go to alarm 1. Same applies to reception messages, if you set them all to 1, it will still only go to alarm 1, thus activate relay 1 only. Other monitors on CAN bus will activate alarms and relays as the messages are received.
- Menu settings 9 to 17 are for the "A" sensor (top sensor). Menu settings 27 to 31, 33 to 35 are for the "B" sensor (bottom sensor). It is therefore possible to program dual gas monitors to send different messages for each sensor.

## 5.4 Binary Input

The binary input can transmit a message on CAN bus when a limit switch is closed.

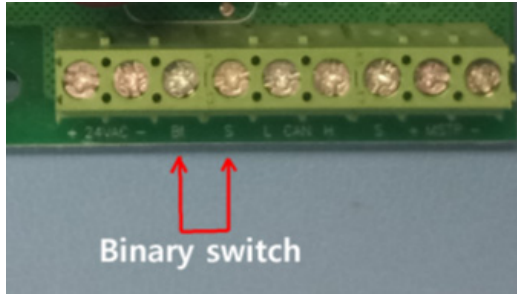

When the "BI" terminal is shorted to the "S" terminal, the gas monitor will send the transmit message entered in menu setting 32 over the CAN bus network. Applications for this include limit switches for actuators, as well as smoke extraction switches commonly used in buildings for firefighters, manual push buttons, and external thermostats (to protect pipes from freezing).

For this example, if you press a button or flip a switch shorting the binary input, a transmit message will be sent to the other gas monitors on CAN bus to activate ventilation.

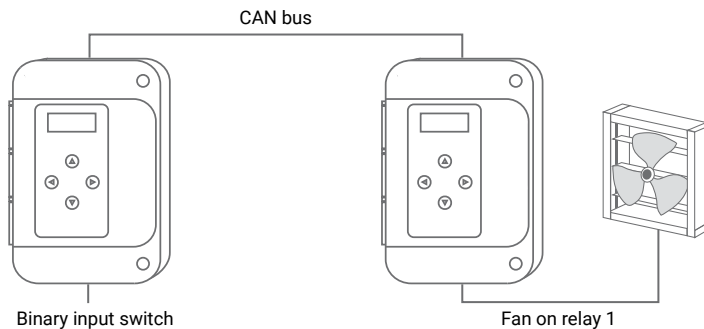

## 5.5 Fault Alarms

Menu setting 59 can be used to transmit a message on the CAN bus network if a fault occurs on any gas monitor (such as too low or high voltage, if a sensor is missing or not replaced correctly, if a sensor needs to be replaced, or if a device loses power or drops off the CAN bus network). Simply set the transmit message you want to send on CAN bus, which can be used to activate a relay, strobe alarm, alert a BMS, etc.

A typical application would be in combination with menu setting 77 (number of devices on CAN bus network). When the wrong number of gas monitors is detected, (aka if any of them loose power because they are damaged, knocked off of the wall, etc.) it will generate a fault. Menu setting 59 can be set to transmit a message again to activate a relay, strobe alarm, alert a BMS, etc. to alert users that a gas monitor has dropped offline.

## 5.6 Equipment Controlled from Dedicated Locations

Belimo gas monitors can control external equipment (fans, actuators, external alarms, etc.) directly through their on-board relays and analog outputs, however if a customer would like all external equipment to be controlled at a specific location (mechanical room, office room, etc.) communication modules and relay units can be used. The -C model gas monitors will transmit their gas readings and alarm statuses through CAN bus to the communication module and relay unit, which in return will control all the external equipment (fans, actuators, external alarms, etc.) from a dedicated location.

Another feature available on communication modules and all gas monitors is the ability to remotely view all devices on the CAN bus network. (This feature by default is turned ON for communication modules and turned OFF for gas monitors. It is configurable per menu setting 56). This allows a communication module to be installed somewhere easily accessible (maintenance room, office room, etc.), so that someone can see what is happening on the entire gas monitoring system and be alerted if any gas monitor goes into alarm.

The communication module will display each device's address, gas type, gas concentration, and alarm level status. The optional on-board relays can be configured to activate at similar or different gas levels in one zone, or in multiple zones. If more relays are needed, a relay unit (C-22G-50) can be added which has four additional relays.

## 5.7 Equipment Controlled Directly from the Gas Monitors

Belimo gas monitors can control external equipment (fans, actuators, external alarms, etc.) directly through their on-board relays and analog outputs. Therefore, the use of a dedicated communication module is optional, and only required if the customer wants all equipment to be controlled at a specific location. When using the gas monitors to control external equipment, starters and air dampers are typically connected to the gas monitor closest to it in each zone.

## 5.8 Relay Outputs

Belimo relays are

- SPDT, 5A @ AC 125 V / 4A @ DC 24 V, non-inductive
- 1x relay available on all -A models
- 2x relays available on all -B models

Belimo gas monitors and communication modules have either 2x, 1x, or no relays depending on the model. All -A models have x1 relay, all -B models have 2x relays, and all -C models have no relays. All Belimo relay units (C-22G-50) have 4x relays.

Relays are activated locally when its corresponding gas level alarm is triggered. Relay 1 activates with alarm level 1 and relay 2 activates with alarm level 2. They can also be activated locally if the binary input / limit switch is shorted, if the high temperature alarm is reached, when programming scheduled ventilation, or if there is an error on the CAN bus network.

Relays can also be activated remotely through CAN bus by any of the reasons previously stated. Activating relays remotely through CAN bus is done through transmit and receive messages.

## 6.0 Network configuration (BACnet MS/TP)

### 6.1 Menu Settings: BACnet MS/TP

Setting 46	<b>Activation of BACnet MS/TP</b> 0 = BACnet MS/TP communication disabled (-) 1 = BACnet MS/TP communication enabled (+) 2 = BACnet MS/TP communication enabled (+), and all gas readings on CAN bus are brought into the BMS through BACnet MS/TP. <i>This allows any -A or -B model to be used as a CAN bus to BACnet MS/TP gateway, to tie the entire CAN bus system into a BMS through BACnet MS/TP.</i>	0/1/2	*0
Setting 47	<b>Device address, BACnet MS/TP</b> <i>All devices on the BACnet MS/TP network must have a unique address. The available addresses are 0 to 127, 0 is a unique address.</i>	0...127	1
Setting 48	<b>Baud rate, BACnet MS/TP (bits per second)</b> 0 = 9600 1 = 19200 2 = 38400 3 = 76800 <i>Power cycle the device when changing the BACnet MS/TP baud rate.</i>	0/1/2/3	3
Setting 53	<b>Maximum MAC address, BACnet MS/TP</b> <i>Used to increase the speed of BACnet MS/TP communication if there are many devices on the network. When changing this, set the BACnet MS/TP maximum MAC address no less than the highest BACnet MAC address on the network, otherwise devices will be hidden.</i>	0...127	127
Setting 54	<b>Troubleshooting tool, CAN bus / Broadband refrigerant monitor zeroing procedure</b> <i>In format XXXYYZZ, where YY is MAC address (in hex) of the device that gives you the BACnet MS/TP token, and ZZ is the MAC address (in hex) of the device that receives the BACnet MS/TP token from you. Example 0305 would mean that your device receives the token from device #3 and passes it to device #5. For refrigerant gas leak detection monitors (22G21-5C), menu setting 54 is used to reset the zero point of the sensor module. This needs to be done after installation.</i>		
Setting 70	Device instance, BACnet MS/TP Enter part 1 (1000 to 4,194,303) Press right arrow Enter part 2 (0 to 999)	0...4,194, 303	60,000 +BMA
Setting 78	<b>Activating CAN bus alarms and relays at the BMS through BACnet MS/TP</b> 0 = Deactivated 1 = CAN bus transmit messages from the BACnet to CAN bus gateway device for alarm 1 is activated via BACnet MS/TP. 2 = CAN bus transmit messages from the BACnet to CAN bus gateway device for alarm 2 is activated via BACnet MS/TP. 3 = CAN bus transmit messages from the BACnet to CAN bus gateway device for alarm 3 is activated via BACnet MS/TP. 4 = CAN bus transmit messages from the BACnet to CAN bus gateway device for alarms 1, 2, and 3 activated via BACnet MS/TP. <i>Allows the ability to activate all CAN bus alarms and relays at the BMS through BACnet MS/TP by sending the CAN bus transmit messages when alarm 1, alarm 2, alarm 3, or all alarms are activated on the -A or -B model used as the BACnet MS/TP to CAN bus gateway device.</i>	0/1/2/3/4	*0

\*0 = inactive

### Ventilation controlled through the BMS

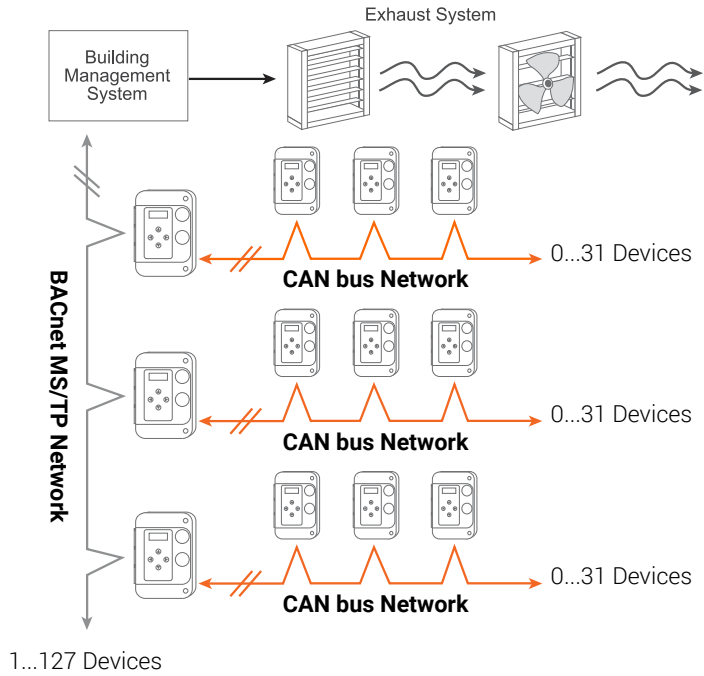

### Ventilation controlled directly by gas monitors

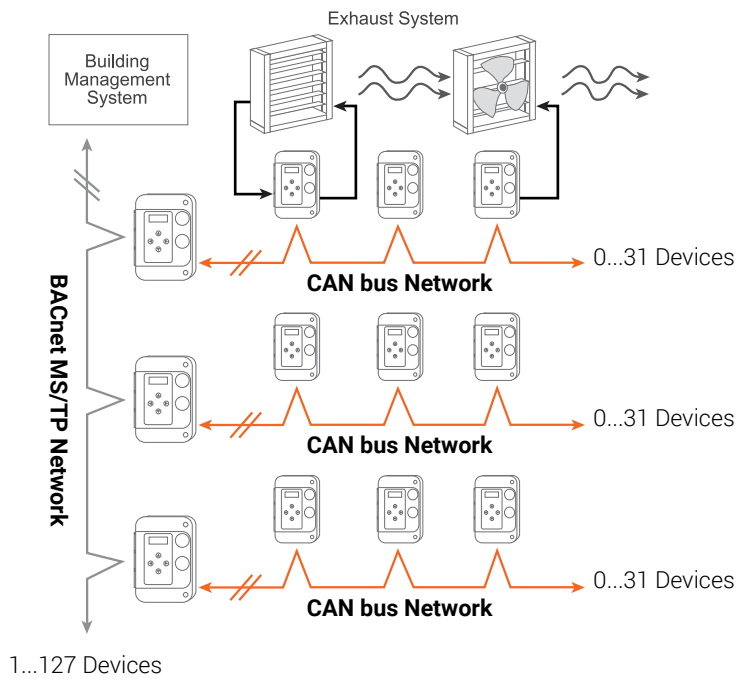

## 6.2 Protocol Implementation Conformance Statement (PICS): BACnet MS/TP

Object Table

TYPE AND INSTANCE	OBJECT NAME	OBJECT PROPERTY	PARAMETER
AV:0	Gas Reading 1	Present value (R)	Gas reading for sensor A (top sensor) if menu setting 46 = 1
AV:1	Gas Reading 2	Present value (R)	Gas reading for sensor B (bottom sensor) if menu setting 46 = 1
AV:2	Ambient Temp.	Present value (R)	Temperature in celsius or fahrenheit
BI:0	Input 1	Present value (R)	Auxiliary input state 0/1
BO:0	Relay 1 / Alarm L1	Present value (R/W)	Alarm 1 and relay 1 status 0/1
BO:1	Relay 2 / Alarm L2	Present value (R/W)	Alarm 2 and relay 2 status 0/1
BO:2	Alarm 3	Present value (R/W)	Alarm 3 status 0/1
AV XYY	Gas reading XYY	Present value (R)	Gas readings for all sensors A (top sensors) and sensors B (bottom sensors) on the CAN bus network if menu setting 46 = 2

X = sensor A (top sensor) or sensor B (bottom sensor)

YY = CAN bus address

Analog value for each gas reading will display description of gas type and scale

## 7.0 Analog output configuration

The analog outputs on all -A model gas monitors and communication modules can be programmed to any output signal desirable to be used with variable speed fans (VFDs) or a building management system (BMS). It is also possible to program a group of gas monitors to share their gas readings with one -A model, which will in turn vary its analog output based on the highest gas reading (by default). This section assumes you already have a working CAN bus network, meaning that all CAN bus addresses and end-of-line jumpers have been set and the CAN bus network has been checked using menu setting 56 (Net).

### 7.1 Default Analog Outputs

Use the jumpers to configure the analog outputs for sensor A (top sensor) and sensor B (bottom sensor) to 2...10 V or 4...20 mA. Set the jumper to the bottom two pins for 2...10 V or to the top two pins for 4...20 mA.

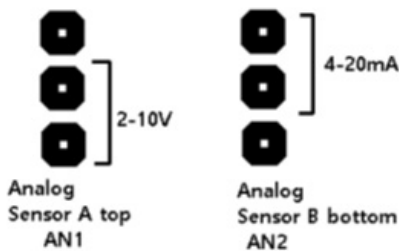

### 7.2 Customized Analog Outputs

MENU SETTING	NAME	DESCRIPTION
40	AnZA	Analog output minimum point for sensor A (top sensor)
41	AnSA	Analog output maximum point for sensor A (top sensor)
42	AnZB	Analog output minimum point for sensor B (bottom sensor)
43	AnSB	Analog output maximum point for sensor B (bottom sensor)

Menu setting 40 (AnZA): To set the analog output minimum point for sensor A (top sensor). To configure AN1 min. value, use a multimeter and place the black lead on the "G" terminal and the red lead on the "AN1" terminal. Adjust to the desired analog output value shown on the multimeter, by adjusting the number on the gas monitor LCD using the ↑ and ↓ buttons. Once the desired value is set, press ↑ and ← at the same time on the gas monitor to save. To change the analog outputs to from VDC to mA, set the correct jumper on the PCB to the top two pins. Always remove the load source when configuring the analog outputs.

**Menu setting 41 (AnSA):** To set the analog output maximum point for sensor A (top sensor). To configure AN1 max. value, follow the steps shown in menu setting 40.

**Menu setting 42 (AnZB):** To set the analog output minimum point for sensor B (bottom sensor). Same process as 40 but place multimeter red lead on AN2.

**Menu setting 43 (AnSB):** To set the analog output maximum point for sensor B (bottom sensor). Same process as 40 but place multimeter red lead on AN2.

All devices on the CAN bus network are able to transmit their gas readings to control the analog outputs on any -A gas monitor based on highest reading wins, an average of the gas readings, or by auto ramping. Please note the -A model can be located anywhere on the CAN bus network and can have any CAN bus address.

#### Customizing Analog Outputs min. and max. Percentages of Scale

MENU SETTING	NAME	DESCRIPTION
60	ADTxA	Analog output transmit channel for sensor A (top sensor)
61	AMinA	Analog output minimum percent of scale for sensor A (top sensor)
62	AMaxA	Analog output, maximum percent of scale for sensor A (top sensor)
63	ADRxA	Analog output receive channel to control local analog output AN1
64	ADTxB	Analog output transmit channel for sensor B
65	AMinB	Analog output minimum percent of scale for sensor B (bottom sensor)
66	AMaxB	Analog output, maximum percent of scale for sensor B (bottom sensor)
67	ADRxB	Analog output receive channel to control local analog output AN2
75	VSD A	Variable speed drive logic

**Menu setting 60 (ADTxA):** A specific CAN bus channel that will transmit the live analog data from sensor A (the top sensor). CAN bus channels are totally separate from the CAN bus transmit or receive messages, therefore if setting 60 (ADTxA) is set to 1, it will not interfere with transmit and receive message 1. This value must be set on all gas monitors that will control the analog outputs.

**Menu setting 61 (AMinA):** Analog output minimum percentage of scale. This value determines at what specific gas concentration from sensor A (the top sensor) the analog output will start to increase from its minimum point (2 V or 4 mA default). The minimum and maximum percentage of scales are set based on the desired set point in relation to the full range of the sensor. This value must be set on all gas monitors that will control the analog outputs.

**Menu setting 62 (AMaxA):** Analog output maximum percentage of scale. This value determines at what specific gas concentration from sensor A (top sensor) the analog output will reach its maximum point (10 V or 20 mA default). The minimum and maximum percentage of scales are set based on the desired set point in relation to the full range of the sensor. This value must be set on all gas monitors that will control the analog outputs.

**Menu setting 63 (ADRxA):** A specific CAN bus channel that will receive the live analog data from sensor A (the top sensor), sensor B (the bottom sensor), or both sensors A and B (the top and bottom) from any/all gas monitors on the CAN bus network. This value must be set on only the gas monitor that physically has the analog outputs to control the VFD. If you have chosen to set menu settings 60 (ADTxA) and 64 (ADTxB) to 1 on all gas monitors, if using AN1, on the -A model device with the analog outputs, menu setting 63 (ADRxA) must be set to 1. The channel can be set to any value between 1 to 255, just as long as the transmit and receive channels match.

**Menu settings 64 (ADTxB), 65 (AMinB), 66 (AMaxB), 67 (ADRxB):** These settings are the same as settings 60, 61, 62, 63 but for sensor B (the bottom sensor). If you wish to combine outputs for sensors A and B, simply select the same channel for sensors A and B. This will allow combined units (CO/NO<sub>2</sub> for example) to control a VFD based on the gas readings of both CO and NO<sub>2</sub>.

**Menu setting 75 (VSD A):** This determines how the variable speed drive logic will operate on the analog (-A) model.

**0:** Highest reading wins: The gas monitor detecting the highest gas concentration will control the analog output.

**1:** Average gas readings: The average of all gas readings will control the analog output. This is not recommended.

**2:** Auto ramping: The analog output will increase by 0.8 volts at one-minute intervals. Every one minute, if the gas level has risen, the ramping will keep going up by 0.8 volts. If the gas level has decreased, the monitor will ramp down by 0.8 volts. When ramping down, the intervals are shortened to 30 seconds. When the gas level falls below the set percentage, the analog output will drop to minimum output.

### 7.3 Practical Application

Let's take this example, a simple 4 gas monitor CAN bus network with 3x -C models, and 1x analog -A model, with the analog outputs set to 2...10 V, and highest reading logic selected.

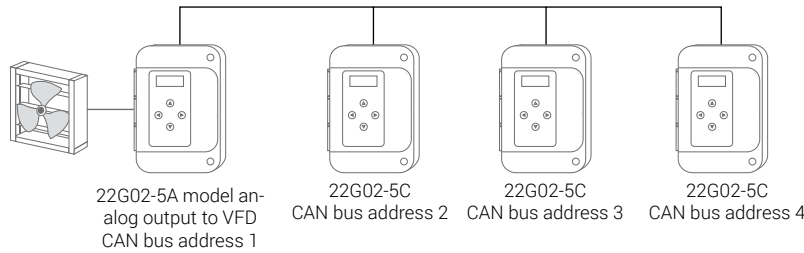

All devices on the CAN bus network are able to transmit their gas readings to control the analog outputs on any -A gas monitor based on highest reading wins, an average of the gas readings, or by auto ramping. Please note the -A model can be located anywhere on the CAN bus network, and can have any CAN bus address.

#### Programming Percentages of Scale

The default analog outputs are controlled 2...10 V / 4...20 mA based on the full range of the sensor.

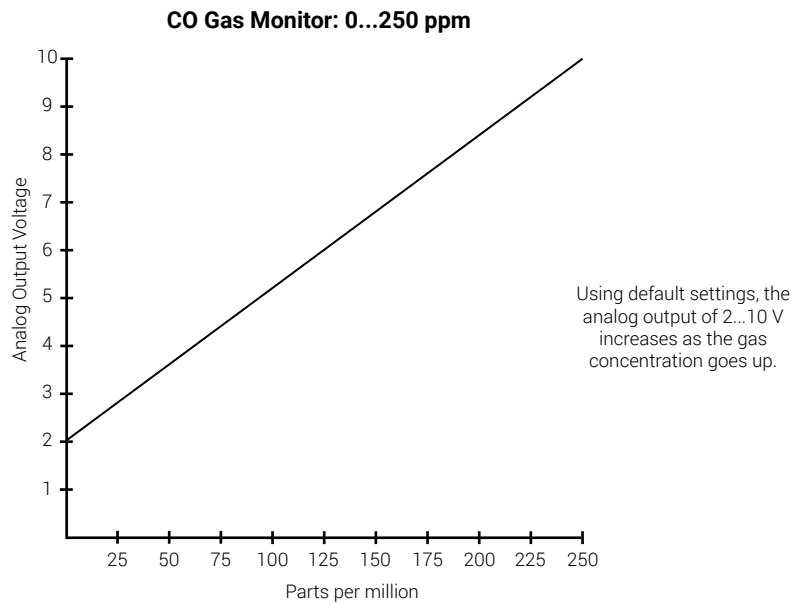

It is also possible to program the gas monitor to stay at the minimum analog output until it reaches a certain gas concentration. In the example below, we set menu setting 61 (minimum percentage of scale) to 10%, which corresponds to 25 ppm CO, since we have a 0...250 ppm CO sensor. This means that the analog output will stay at 2 V until the gas reading reaches 10% of the full scale or 25 ppm.

It is also possible to program the gas monitor to reach its maximum analog output at a specific gas concentration. In the example below, we set menu setting 62 (maximum percentage of scale) to 30%, which corresponds to 75 ppm CO, since we have a 0...250 ppm CO sensor. This means that the analog output will jump to 10 V when the gas reaches 30% of the full scale or 75 ppm.

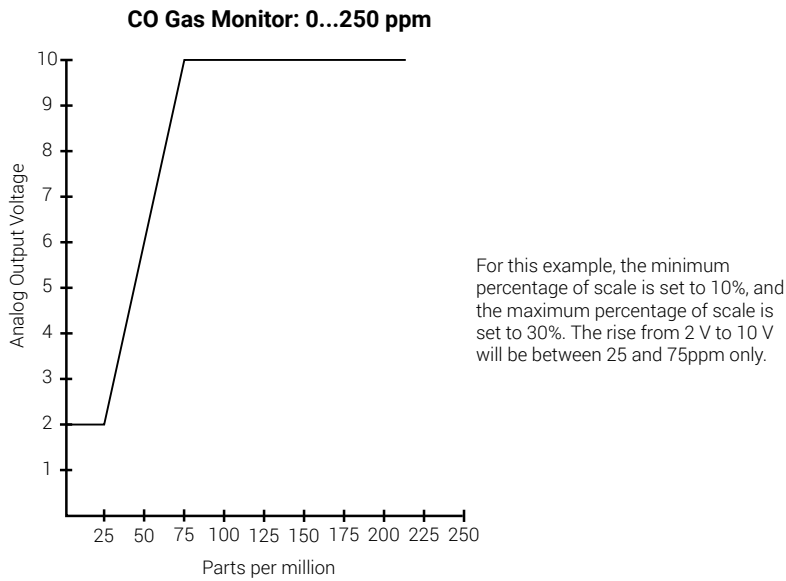

Calculations to convert ppm to % of full scale of a 0...250 ppm CO gas monitor:

$$(\text{Set point} / \text{full scale}) \times 100 = \% \text{ of full scale}$$

$$\text{Minimum point (CO)} = (25 \text{ ppm} / 250 \text{ ppm}) \times 100 = 10\%$$

$$\text{Maximum point (CO)} = (75 \text{ ppm} / 250 \text{ ppm}) \times 100 = 30\%$$

The analog outputs need to be configured only on the device that physically has the analog outputs.

MENU SETTING	SET VALUE	DESCRIPTION
60	1	Set to channel 1 on all gas monitors
61	10	Set to 10% (25 ppm) for CO on -A model only
62	30	Set to 30% (75 ppm) for CO on -A model only
63	1	Set to channel 1 on -A model only
64	0	Default set to 0. No second sensor
65	0	Default set to 0% (0 ppm). No second sensor
66	100	Default set to 100% (sensor dependent). No second sensor
67	0	Default set to 0. No second sensor
75	0	Default set to 0. Highest reading wins. On -A model only.

**Customizing Analog Outputs min. and max. Percentages of Scale**

Let's take the same example, a simple 4 gas monitor CAN bus network with 3x -C models, and 1x analog -A model, with the analog outputs set to 2...10 V, and highest reading logic selected. For this more complicated example, all 4 gas monitors detect both CO (0...250 ppm) and NO<sub>2</sub> (0...10 ppm).

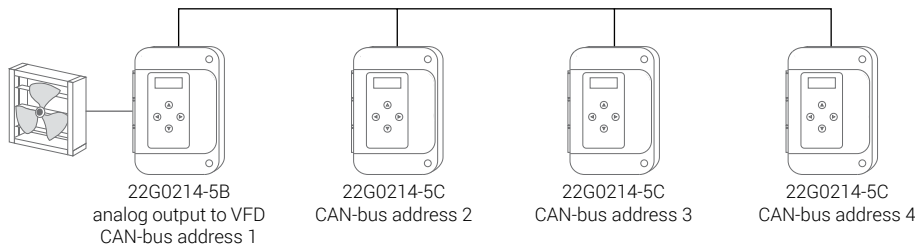

**CO and NO<sub>2</sub> Gas Monitor: CO: 0...250 ppm, NO<sub>2</sub>: 0...10 ppm**

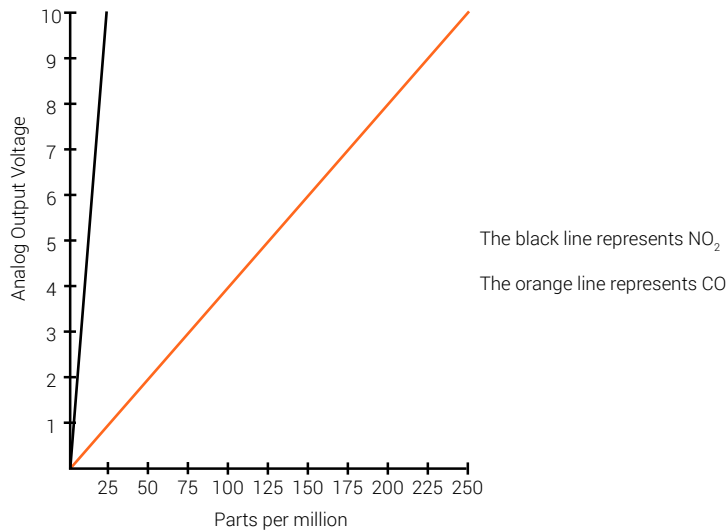

In the example below, we set menu setting 61 (minimum percentage of scale) to 10%, which corresponds to 25 ppm CO and 62 (maximum percentage of scale) to 30%, which corresponds to 75 ppm CO, since we have a 0...250 ppm CO sensor. We also set menu setting 65 (minimum percentage of scale) to 5%, which corresponds to 0.5 ppm NO<sub>2</sub> and 66 (maximum percentage of scale) to 20%, which corresponds to 2 ppm NO<sub>2</sub>, since we have a 0...10 ppm NO<sub>2</sub> sensor.

Calculations to convert ppm to % of full scale of a 0...250 ppm CO and a 0...10 ppm NO<sub>2</sub> gas monitor:

(Set point / full scale) \* 100 = % of full scale

Minimum point (CO) = (25 ppm / 250 ppm) x 100 = 10%

Maximum point (CO) = (75 ppm / 250 ppm) x 100 = 30%

Minimum point (NO<sub>2</sub>) = (0.5 ppm / 10 ppm) x 100 = 5%

Maximum point (NO<sub>2</sub>) = (2.0 ppm / 10 ppm) x 100 = 20%

The analog outputs need to be configured only on the device that physically has the analog outputs.

MENU SETTING	SET VALUE	DESCRIPTION
60	1	Set to channel 1 on all gas monitors
61	10	Set to 10% (25 ppm) for CO on -A model only
62	30	Set to 30% (75 ppm) for CO on -A model only
63	1	Set to channel 1 on -A model only
64	1	Set to channel 1 on all gas monitors
65	5	Set to 5% (0.5 ppm) for NO <sub>2</sub> on -A model only
66	20	Set to 20% (2 ppm) for NO <sub>2</sub> on -A model only
67	1	Set to channel 1 on -A model only
75	0	Default set to 0. Highest reading wins. On -A model only.

The analog drive transmit and receive channels (menu settings 60, 63, 64, 67) used will be set to 1. The selection of the drive logic to be applied to the -A model (menu setting 75) will be set to the highest reading.

We want the fan to turn on at 25 ppm for CO or 0.5 ppm for NO<sub>2</sub>, and to reach full speed at 75 ppm of CO or 2 ppm NO<sub>2</sub>, so we must calculate the percentages we want to input for menu settings 61 and 62 for CO and menu settings 65 and 66 for NO<sub>2</sub>.

Note that we have set the same channel transmission for sensors A and B, CO and NO<sub>2</sub>. This means that both sensors are operating on a single analog output to control the VFD, in this case on AN1. This sequence must be set to all 4 gas monitors. The 3 "C" models do not have an analog output, so you do not need to program their reception channels (menu settings 63 and 67).

# 8.0 Maintenance

## 8.1 Calibration: Overview

All gas monitor sensor modules are factory calibrated but are required to be recalibrated at a minimum of once per year. When installing gas monitors in locations above 2000 ft [610 m], it is recommended to perform calibration upon installation.

## 8.2 Calibration: Required Equipment

Before calibrating any Belimo gas monitors you will need to purchase the following equipment:

- Belimo calibration kit. To calibrate CO, NO<sub>2</sub>, CO<sub>2</sub>, NH<sub>3</sub>, CH<sub>4</sub>, C<sub>3</sub>H<sub>8</sub>, H<sub>2</sub>, H<sub>2</sub>S, CL<sub>2</sub>, O<sub>2</sub> Leak and O<sub>2</sub> Dep., purchase the (A-22G-A22) calibration kit consisting of a regulator with a C10 connection and a calibration cap and hose. To calibrate the broadband refrigerant gas monitor, purchase the (A-22G-A08) refrigerant calibration kit consisting of a regulator with a C10 connection and the refrigerant calibration cap and hose.
- Zero-point calibration gas bottle. To calibrate the zero-point of CO, NO<sub>2</sub>, CO<sub>2</sub>, NH<sub>3</sub>, H<sub>2</sub>S, CL<sub>2</sub>, purchase either a nitrogen (N<sub>2</sub>) or a pure air gas bottle. To calibrate the zero-point of CH<sub>4</sub>, C<sub>3</sub>H<sub>8</sub>, and H<sub>2</sub> purchase a pure air gas bottle. To calibrate the zero-point of O<sub>2</sub> Leak and O<sub>2</sub> Dep., purchase a nitrogen (N<sub>2</sub>) gas bottle. Use a NIST traceable gas bottle with a C10 connection.
- Span-point calibration gas bottle. To calibrate the span-point of CO, NO<sub>2</sub>, CO<sub>2</sub>, NH<sub>3</sub>, H<sub>2</sub>S, CL<sub>2</sub>, O<sub>2</sub> Leak, O<sub>2</sub> Dep., and refrigerants purchase a span gas bottle with a gas concentration within the measuring range of the gas monitor, that either is balance nitrogen or balance air. To calibrate the span-point of CH<sub>4</sub>, C<sub>3</sub>H<sub>8</sub>, and H<sub>2</sub>, purchase a gas bottle that is balance air. Use a NIST traceable gas bottle with a C10 connection.

## 8.3 Calibration: CO, NO<sub>2</sub>, NH<sub>3</sub>, CH<sub>4</sub>, C<sub>3</sub>H<sub>8</sub>, H<sub>2</sub>, H<sub>2</sub>S, CL<sub>2</sub>, O<sub>2</sub>

### Zero Point Calibration:

1. Before calibrating, ensure the gas monitor has been powered long enough for the sensor module to fully stabilize.
2. Press → to enter the menu.
3. Press ↑ and → at the same time to enter the calibration menu. The screen should display SAZ.
  - \*When calibrating the zero-point of the top sensor (sensor A), stay at SAZ.
  - \*When calibrating the zero-point of the bottom sensor (sensor B), press → button twice to get to SBZ.
4. Connect the zero-point gas bottle to the Belimo regulator and fit the calibration cap over the correct sensor hole on the gas monitor front cover. Make sure that the front cover is screwed securely to the base.
5. While at SAZ (sensor A) or SBZ (sensor B), open the regulator and flood the sensor with the zero-point gas at a flow rate of 0.5 LPM for 90 seconds or until the gas reading stabilizes.
6. After the gas reading stabilizes and while still flooding the zero-gas over the sensor, press and hold the ↑ button until the bottom right number (the zero-point adjustment number) is zero.

7. Press the ↓ button until the top right number (the live gas reading) is zero. Once the top value is zero, press the ↓ button five more times.
8. Press ↑ and ← at the same time to save.  
\*If the gas monitor is detecting two gases this process needs to be done for both sensors. Repeat this process for SBZ.

#### **Span Point Calibration:**

9. Press → to enter the menu.
10. Press ↑ and → at the same time to enter the calibration menu. The screen should display SAZ. Press → to get to SAS.  
\*When calibrating the span-point of the top sensor (sensor A), stay at SAS.  
\*When calibrating the span-point of the bottom sensor (sensor B), press → button twice to get to SBS.
11. Connect the span-point gas bottle to the Belimo regulator and fit the calibration cap over the correct sensor hole on the gas monitor front cover. Make sure that the front cover is screwed securely to the base.
12. While at SAS (sensor A) or SBS (sensor B), open the regulator and flood the sensor with the span-point gas at a flow rate of 0.5 LPM for 90 seconds or until the gas reading stabilizes.
13. After the gas reading stabilizes and while still flooding the span-gas over the sensor, press the ↑ or ↓ button until the top right number (the live gas reading) reads the same value as the concentration of the span-gas bottle.  
\*Over time as the gas monitor is installed and working, the gain of the sensor (the bottom right value) will decrease. When the span / gain value reaches 200 or below, the sensor must be replaced and no longer recalibrated. To replace any sensor module, please see corresponding section in the operating manual.
14. Press ↑ and ← at the same time to save.  
\*If the gas monitor is detecting two gases this process needs to be done for both sensors. Repeat this process for SBS. Remember to use the correct span-point calibration gas bottle.

## **8.4 Calibration: CO<sub>2</sub>**

#### **Zero Point Calibration:**

\*No zero point calibration required for infrared ABC logic and infrared dual channel sensors.

#### **Span Point Calibration:**

1. Press → to enter the menu.
2. Press ↑ and → at the same time to enter the calibration menu. The screen should display SAZ. Press → to get to SAS.  
\*When calibrating the span-point of the top sensor (sensor A), stay at SAS.  
\*When calibrating the span-point of the bottom sensor (sensor B), press → button twice to get to SBS.
3. Connect the span-point gas bottle to the Belimo regulator and fit the calibration cap over the correct sensor hole on the gas monitor front cover. Make sure that the front cover is screwed securely to the base.

4. While at SAS (sensor A) or SBS (sensor B), open the regulator and flood the sensor with the span-point gas at a flow rate of 0.5 LPM for 90 seconds or until the gas reading stabilizes.
5. After the gas reading stabilizes and while still flooding the span-gas over the sensor, press the ↑ or ↓ button until the top right number (the live gas reading) reads the same value as the concentration of the span-gas bottle.
 

\*Over time as the gas monitor is installed and working, the gain of the sensor (the bottom right value) will decrease. When the span / gain value reaches 200 or below, the sensor must be replaced and no longer recalibrated. To replace any sensor module, please see corresponding section in the operating manual.
6. Press ↑ and ← at the same time to save.
 

\*If the gas monitor is detecting two gases this process needs to be done for both sensors. Repeat this process for SBS. Remember to use the correct span-point calibration gas bottle.

## 8.5 Calibration: Broadband Refrigerant

### Zero Point Calibration:

1. Before calibrating, ensure the gas monitor has been powered long enough for the sensor module to fully stabilize.
2. Press and hold → to reach menu setting 54 (ZeroC) and press ↑ and ↓ buttons at the same time. Wait 2 minutes, then verify that setting 54 (ZeroC) displays a value of "0±10", if not repeat the process.
3. Press ↑ and → at the same time to enter the calibration menu. The screen should display SAZ.
 

\*The infrared broadband refrigerant gas monitor has only one sensor located in the top sensor slot (sensor A). When calibrating the zero-point, stay at SAZ.
4. Connect the zero-point gas bottle to the Belimo regulator and fit the calibration cap over the correct sensor hole on the gas monitor front cover. Make sure that the front cover is screwed securely to the base.
5. While at SAZ (sensor A), open the regulator and flood the sensor with the zero-point gas at a flow rate of 0.5 LPM for 90 seconds or until the gas reading stabilizes.
6. After the gas reading stabilizes and while still flooding the zero-gas over the sensor, press and hold the ↑ button until the bottom right number (the zero-point adjustment number) is zero.
7. Press the ↓ button until the top right number (the live gas reading) is zero. Once the top value is zero, press the ↓ button five more times.
8. Press ↑ and ← at the same time to save.

### Span Point Calibration:

9. Press → to enter the menu.
10. Press ↑ and → at the same time to enter the calibration menu. The screen should display SAZ. Press → to get to SAS.
 

\*The infrared broadband refrigerant gas monitor has only one sensor located in the top sensor slot (sensor A). When calibrating the zero-point, stay at SAZ.

11. Connect the span-point gas bottle to the Belimo regulator and fit the calibration cap over the sensor hole on the gas monitor front cover. Make sure that the front cover is screwed securely to the base.
12. While at SAS (sensor A), open the regulator and flood the sensor with the span-point gas at a flow rate of 0.5 LPM for 90 seconds or until the gas reading stabilizes.
13. After the gas reading stabilizes and while still flooding the span-gas over the sensor, press the ↑ or ↓ button until the top right number (the live gas reading) reads the same value as the concentration of the span-gas bottle.  
 \*Over time as the gas monitor is installed and working, the gain of the sensor (the bottom right value) will decrease. When the span / gain value reaches 200 or below, the sensor must be replaced and no longer recalibrated. To replace any sensor module, please see corresponding section in the operating manual.
14. Press ↑ and ← at the same time to save.

## 8.6 Sensor Module: Sensing Technology

GAS TYPE	GAS TYPE IDENTIFICATION NUMBER	SENSOR MODULE SENSING TECHNOLOGY
Carbon monoxide (CO)	02	Electro-Chemical
Carbon monoxide (CO null H <sub>2</sub> )	03	
Nitrogen dioxide (NO <sub>2</sub> )	14	
Ammonia (NH <sub>3</sub> )	04	
Hydrogen sulfide (H <sub>2</sub> S)	16	
Chlorine (CL <sub>2</sub> )	17	
Oxygen leak (O <sub>2</sub> Leak)	22	
Oxygen depletion (O <sub>2</sub> Dep.)	23	
Methane/Natural gas (CH <sub>4</sub> )	05	Catalytic
Propane (C <sub>3</sub> H <sub>8</sub> )	06	
Hydrogen (H <sub>2</sub> )	08	
Carbon dioxide (CO <sub>2</sub> , 0...2000 ppm)	15-003	Infrared ABC Logic
Carbon dioxide (CO <sub>2</sub> , 0...5000 ppm)	15-005	Infrared Dual Channel
Carbon dioxide (CO <sub>2</sub> , 0...10000 ppm)	15-006	
Infrared Broadband refrigerant (IR)	21	Infrared Broadband

## 8.7 Sensor Module: Installation and Replacement

Whenever a sensor module is installed or replaced, the new sensor module needs to be registered. If not registered correctly, the gas monitor will beep every minute, the display will flash, and the display will show an error code (ERR=S, FAULT Code).

\*When adding or replacing a sensor module to an existing gas monitor, if the gas monitor was not initially intended to detect the specific gas, consider that the product side label will be incorrect, the alarm set points need to be reprogrammed via menu setting 76 (RST P), and the installation height may need to be changed.

\*For monitoring gases of different densities in one gas monitor, Belimo offers a remote enclosure (A-22G-A14), to remotely install one sensor module.

\*To reprogram the alarm level set points, go to programming setting 76 (RSTP) and change the value to either A, B, or A+B (depending on which sensor was replaced or swapped). Once changed, press the ↑ and ← buttons at the same time to save.

Install or replace sensor module (same gas as previous).

1. Open the gas monitor front cover and remove the current sensor module consisting of the small green PCB board with the sensing element attached.
2. Install the new sensor module by removing it from the sealed bag and inserting the metal pins into the correct location on the gas monitor PCB board.
3. Press → to enter the programming menu
4. Press ↑ and → at the same time to enter the calibration menu. The screen should show SAZ.

\*When replacing the top sensor module (sensor A), stay at SAZ.

\*When replacing the bottom sensor module (sensor B), press the → button twice to get to SBZ.

5. Press ↑ and ← at the same time to save.
6. Press and hold the ← to return to the home screen.

Install or replace sensor module (different gas than previous)

1. Open the gas monitor front cover and remove the current sensor module consisting of the small green PCB board with the sensing element attached.
2. Install the new sensor module by removing it from the sealed bag and inserting the metal pins into the correct location on the gas monitor PCB board.
3. Press → to enter the programming menu
4. Press ↑ and → at the same time to enter the calibration menu. The screen should show SAZ.

\*When replacing the top sensor module (sensor A), stay at SAZ.

\*When replacing the bottom sensor module (sensor B), press the → button twice to get to SBZ.

5. Press ↑ and ← at the same time to save.
6. Press and hold the ← to return to the home screen.
7. Press and hold → to get to menu setting 76 (RST P) and change the value to either A, B, or A+B (depending on which sensor was installed or replaced).
8. Press ↑ and ← at the same time to save.
9. Press and hold the ← to return to the home screen.

\*If the sensor module was registered correctly, after a minute or two the gas monitor will show FAULT Code 00, meaning the error was cleared, and it will stop beeping and flashing. If the error does not clear, it may be because the pins were not installed correctly. Please remove the sensor module and repeat the steps.

\*It is not advised to install two catalytic sensor modules in a single gas monitor, including CH<sub>4</sub>, C<sub>3</sub>H<sub>8</sub>, and H<sub>2</sub>, as it creates too much power draw upon activation of relays and alarms causing the gas monitor to not function properly.

## 8.8 Sensor Module: Expected Life Span and End of Life

All sensor modules have an expected life span and an end of life. The expected life span is how long the sensor module will last (under normal conditions) until it should be replaced with a new one. Please note that the exact lifespan of the sensor module is heavily dependent on the application, including how dirty the environment is and how much of the target gas is present in the environment.

The end of life is a safety precaution, and it is how long the sensor module can stay powered in the gas monitor until the gas monitor will go into alarm to tell the end user it is time to replace it.

APPLICATION	GAS TYPE	NOMENCLATURE	EXPECTED LIFESPAN (YEARS)	END OF LIFE (YEARS)
<b>Vehicle Emissions</b>	Carbon monoxide (CO)	02	5...8	10
	Carbon monoxide (CO null H <sub>2</sub> )	03	2...4	5
	Nitrogen dioxide (NO <sub>2</sub> )	14	2...4	5
<b>Indoor Air Quality</b>	Carbon dioxide (CO <sub>2</sub> )	15-003	10	13
	Carbon dioxide (CO <sub>2</sub> )	15-005	10	13
	Carbon dioxide (CO <sub>2</sub> )	15-006	10	13
<b>Combustible and Toxic Gases</b>	Ammonia (NH <sub>3</sub> )	04	2...4	5
	Methane/Natural gas(CH <sub>4</sub> )	05	4...7*	9*
	Propane (C <sub>3</sub> H <sub>8</sub> )	06	3...5*	8*
	Hydrogen (H <sub>2</sub> )	08	4...7*	9*
	Hydrogen sulfide (H <sub>2</sub> S)	16	2...4	5
	Chlorine (CL <sub>2</sub> )	17	2...4	5
	Oxygen leak (O <sub>2</sub> Leak)	22	3...6	8
	Oxygen depletion (O <sub>2</sub> Depletion)	23	3...6	8
	Argon (Ar), (O <sub>2</sub> Depletion)	23	3...6	8
	Oxygen depletion (O <sub>2</sub> Dep.) *Argon: Ar *Helium: He *Nitrogen: N	23	3...6	8
Nitrogen (N <sub>2</sub> ), (O <sub>2</sub> Depletion)	23	3...6	8	
<b>Refrigerant Gas Leak Detection</b>	Infrared Broadband refrigerant (IR)	21	5...10	15

\* Methane/Natural gas (CH<sub>4</sub>), Propane (C<sub>3</sub>H<sub>8</sub>), and Hydrogen (H<sub>2</sub>) sensor modules are required to be replaced annually when used in more critical environments, and are not recommended to be re-calibrated.

## 8.9 Fault Monitoring

FAULT CODE	MESSAGE
00	Error cleared (no error)
01	No sensor
02	Low voltage
04	High voltage
08	Sensor A missing or not registered
10	Sensor B missing or not registered
18	Both sensors missing or not registered
20	Sensor A end of life (need to replace sensor)
40	Sensor B end of life (need to replace sensor)
60	Both sensors end of life
80	CAN bus error: Qty not matching option 77
Err-S	Missing sensors

### Notes:

- For 22Gxx-5A & C-22G-5A model, any fault from above table will turn the corresponding analog output to 0 V/0mA
- On BACnet MS/TP, any fault from the above table will change the system status of the device object to non operational.

Please contact Belimo technical support with any fault codes not in this list.

### **BELIMO Americas**

#### **USA Locations**

33 Turner Road, Danbury, CT 06810  
 1049 Fortunato Loop, Sparks, NV 89436  
 Tel. 800-543-9038, customerservice@us.belimo.com

#### **Canada Location**

2495 Meadowpine Blvd., Unit #2 Mississauga, Ontario L5N 6C3  
 Tel. 866-805-7089, orders.ca@ca.belimo.com

#### **BELIMO Brasil Comércio de Automação Ltda.**

Rua Barbalha, 251, São Paulo/SP, Brazil  
 Tel: 55 11 3643-5656, atendimentoaocliente@br.belimo.com

#### **BELIMO Mexico**

Av. Insurgentes Sur 1602, Col. Credito Constructor, Del. Benito Juarez, Mexico City 03940  
 Tel: 55 4125 7890, servicioalcliente@mx.belimo.com

#### **Latin America and the Caribbean Customer Service**

Tel. +1 905-712-3118, Orders.LatAm@us.belimo.com

[www.belimo.com](http://www.belimo.com)

